

Guardian 6200 Production Safety Analyzer Instruction Manual

Form 150528/A6

©QuadTech, Inc., 2000
5 Clock Tower Place, 210 East
Maynard, Massachusetts, U.S.A. 01754
June 2002

Telephone	978-461-2100
Sales	800-253-1230
Facsimile	978-461-4295
Website	www.quadtech.com

The material in this manual is for informational purposes only and is subject to change, without notice. QuadTech assumes no responsibility for any error or for consequential damages that may result from the misinterpretation of any procedures in this publication.

WARNING

Potentially dangerous voltages may be present on front and rear panel terminals. Follow all warnings in this manual when operating or servicing this instrument. Dangerous levels of energy may be stored in capacitive devices tested by this unit. Always make sure the high voltage indicator is **OFF** when connecting or disconnecting the device under test.



Product will be marked with this symbol (ISO#3864) when it is necessary for the user to refer to the instruction manual in order to prevent injury or equipment damage.



Product marked with this symbol (IEC417) indicates presence of direct current.



Product will be marked with this symbol (ISO#3864) when voltages in excess of 1000V are present.

Contents

Warranty	7
Specifications	9
Accessories	13
Safety Precautions	15
Condensed Operating Instructions	17

Introduction - Section 1

1.1	Unpacking and Inspection	21
1.2	Product Overview	21
1.3	Controls and Indicators	22
	1.3.1 Front Panel Controls and Indicators	22
	1.3.2 Rear Panel Controls and Connectors	24
1.4	Installation	26
	1.4.1 Dimensions	26
	1.4.2 Instrument Positioning	26
	1.4.3 Power Requirements	26
	1.4.4 Safety Inspection	28

Operation - Section 2

2.1	Terms and Conventions	29
2.2	Start-Up	33
2.3	Programming Hipot Tests	34
	2.3.1 Programming an AC Hipot Test	35
	2.3.2 Programming a DC Hipot Test	36
2.4	Programming an Insulation Resistance Test	37
2.5	Programming a Ground Bond Test	38
2.6	Programming an Earth Line Leakage Current Test	39
	2.6.1 Leakage Current Test Conditions	39
	2.6.1.1 Faults	39
	2.6.1.2 Line Voltage/Frequency	39
	2.6.1.3 Measurement Equipment	40
	2.6.2 G6200 LC Test Parameters	41
	2.6.2.1 G6200 Connection to DUT	42
	2.6.2.2 Earth LC Programming Instructions	43
2.7	Pause Mode	44
2.8	Programming a Multi-Step Test	45
2.9	Storing a Test Setup	46
	2.9.1 Storing a Single Step Test	46
	2.9.2 Storing a Multi-Step Test	47
2.10	Instrument Zeroing/Offset	48

Contents (Continued)

Operation - Section 2 (Continued)

2.11	Connection To Device Under Test	50
2.12	Measurement Procedure	55
2.13	Initial Parameter Setting	56
2.13.1	General Setting	59
2.13.1.1	Contrast.....	59
2.13.1.2	Beep Vol.	59
2.13.1.3	Scan NO.	60
2.13.1.4	Fail Retest	60
2.13.1.5	Print PASS	60
2.13.1.6	Print FAIL	60
2.13.1.7	Timer U/D	60
2.13.2	Timing Setting	60
2.13.2.1	Pass Hold	60
2.13.2.2	Step Hold	60
2.13.2.3	Judg. Wait	61
2.13.2.4	DC Wait	61
2.13.3	Special Setting	61
2.13.3.1	AC-V Freq	61
2.13.3.2	G-R Freq	61
2.13.3.3	G-R Volt	62
2.13.3.4	WV A Range	62
2.13.3.5	IR A Range	62
2.13.3.6	Software AGC	62
2.13.3.7	Password	62
2.13.3.8	G-R Cont.	64
2.13.3.9	IEC601-1	64
2.13.3.10	Lock Rcl	64
2.13.3.11	Discharge	64
2.13.4	Remote Setting	65
2.13.4.1	GPIB Addr	65
2.13.4.2	Baud Rate	65
2.13.4.3	GPIB Comp	65
2.14	Front Panel Lockout	65
2.15	Clear Setup Memory.....	66
2.16	Software Version Display	66

Contents (Continued)

Interface - Section 3

3.1	Remote.....	67
3.2	RS232 Interface	70
	3.2.1 PIN Configuration	70
	3.2.2 RS232 Specifications.....	71
	3.2.3 RS232 Commands	71
	3.2.4 Sample QuickBASIC Program.....	72
3.3	IEEE-488 Interface	73
	3.3.1 PIN Configuration	73
	3.3.2 IEEE-488 Interface Codes and Messages	74
	3.3.3 IEEE-488 Interface Commands.....	75
	3.3.4 Listener Functions	76
	3.3.5 Talker Functions	81
	3.3.6 Sample QuickBASIC Program	84
3.4	Printer Interface	86
3.5	Scanner Interface	87
	3.5.1 Scanner Accessories	87
	3.5.2 Internal Scanner Connections	87
	3.5.3 External Scanner Connections	88
	3.5.4 External Scanner Programming	88

Service & Calibration - Section 4

4.1	General.....	95
4.2	Instrument Return	95
4.3	Calibration	95
	4.3.1 Calibration Procedure	96
	4.3.2 AC Voltage Calibration.....	98
	4.3.3 DC Voltage Calibration.....	99
	4.3.4 IR Voltage Calibration	100
	4.3.5 AC Current Calibration	101
	4.3.6 DC Current Calibration	103
	4.3.7 Ground Continuity Calibration.....	105
	4.3.8 WAC and WDC ARCing Calibration	108
	4.3.9 Leakage Current Current Meter Calibration	109
	4.3.10 Leakage Current Power Meter Calibration	111
	4.3.11 IR Resistor Calibration	114
	4.3.12 Finalize Calibration	116
4.4	Error Messages	116

Warranty



QuadTech warrants that Products are free from defects in material and workmanship and, when properly used, will perform in accordance with QuadTech's applicable published specifications. If within one (1) year after original shipment it is found not to meet this standard, it will be repaired, or at the option of QuadTech, replaced at no charge when returned to a QuadTech service facility.

Changes in the Product not approved by QuadTech shall void this warranty.

QuadTech shall not be liable for any indirect, special or consequential damages, even if notice has been given of the possibility of such damages.

This warranty is in lieu of all other warranties, expressed or implied, including, but not limited to any implied warranty or merchantability or fitness for a particular purpose.

SERVICE POLICY

QuadTech's service policy is to maintain product repair capability for a period of at least five (5) years after original shipment and to make this capability available at the then prevailing schedule of charges.

Specifications

Dielectric Strength

AC Output Voltage:	Range: 0.05 to 5kV AC, in 1V steps Regulation: \pm (1% of setting +5V) Frequency: 50/60Hz selectable
Voltage Display:	Accuracy: \pm (1% of reading +5V) Resolution: 1V steps
AC Current Display:	Total current Range: 1 μ A to 40mA AC, in 1 μ A or 10 μ A steps Accuracy*: \pm (1% of reading + 5 μ A or 10 μ A)
DC Output Voltage:	Range: 0.05 to 6kV DC, in 1V steps
Voltage Display:	Accuracy: \pm (1% of reading +5V) Resolution: 1V steps
DC Current Display:	Range: 0.1 μ A to 0.3mA DC, in 0.1 μ A steps 0.3mA to 3mA DC, in 1 μ A steps 3mA to 20mA DC, in 10 μ A steps Accuracy*: \pm (1% of reading + 0.5 μ A or 5 μ A or 50 μ A)

Insulation Resistance

Insulation Resistance:	Voltage: 50 - 1000V DC in 1V steps Accuracy: \pm (1% of reading + 5V) Range: 100k Ω - 50G Ω (voltage dependent) Accuracy: \pm 5% \geq 500V, 10M Ω - 1G Ω \pm 10% \geq 500V, 1G Ω - 10G Ω \pm 15% \geq 500V, 10G Ω - 50G Ω \pm 10% < 500V, 100k Ω - 1G Ω
-------------------------------	---

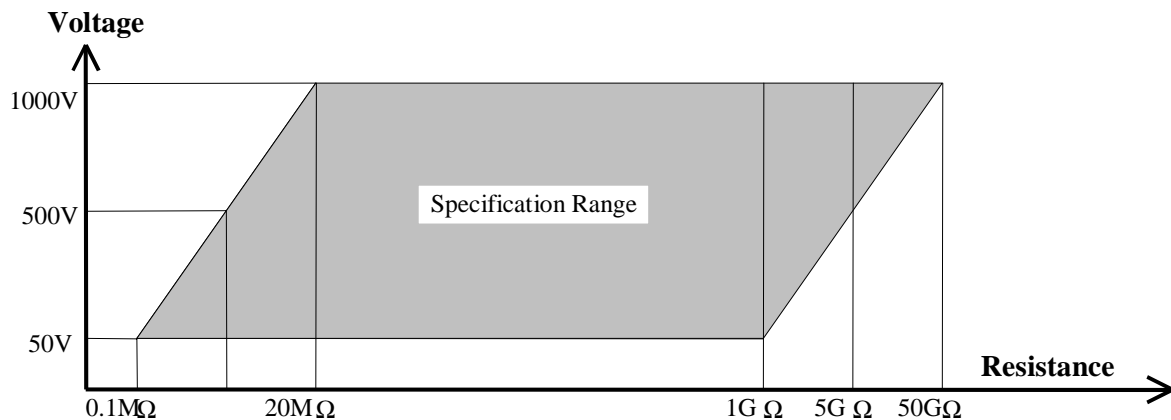

* At Reference 1.2kV with resistive load.

Specifications (Continued)

Ground Continuity / Ground Bond

Output Current:	Range:	1.0 to 30.0A AC, setting 0.01A/step
	Accuracy:	\pm (1% of setting + 0.3A) \pm (1% of reading +0.5A)
	Frequency:	50/60Hz, 6 to 15V
Resistance:	Range:	0.1m Ω - 510.0m Ω , 4 digits, Hi Limit
	Accuracy:	\pm (1% of reading +0.5m Ω)

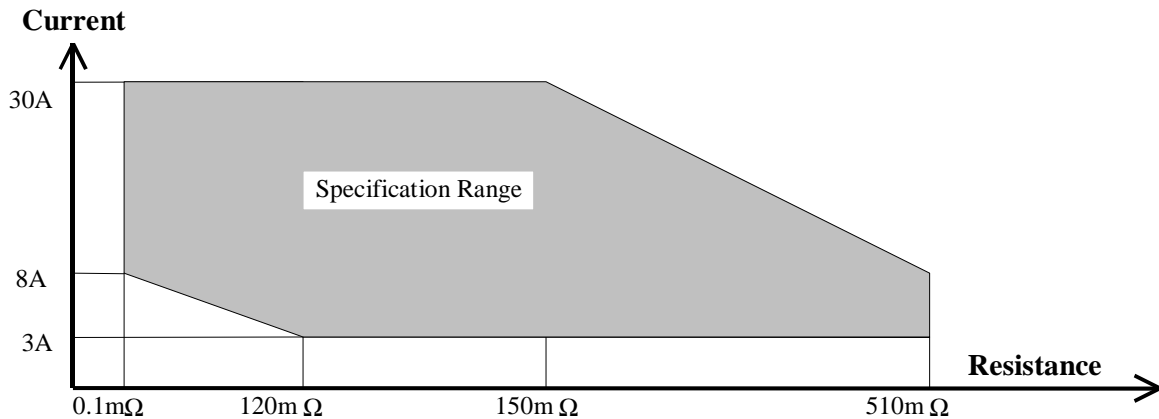

Line Leakage Current

Simulation Circuit:	UL544NP, UL544P, UL1563, UL2601-1 & IEC601-1 UL1950, UL3101-1 & IEC950
Test Mode:	Normal, Reverse, Single Fault Normal, Single Fault Reverse
Current Trip Limits:	0.1 μ A – 9.999mA, 1 μ A resolution
Power Measurement:	Voltage: 0V – 300V AC
	Current: 0A – 10A AC
	Volts/Amps (VA): 0 – 2200VA

ARC Detection

Detection Current:	Range:	Off, 1mA – 40mA AC, 1mA – 20mA DC
Pulse Width:	Minimum:	10 μ s

Specifications (Continued)

General Features

Limits:	Hi/Lo Programmable during Test Time (Lo can be set to Off for Hipot & GC, Hi can be set to Off for IR) Hi/Lo Programmable during Ramp Time (AC/DC Hipot only) (Both limits can be set to OFF)		
Indication:	Pass/fail LEDs, audible sound		
Buzzer Level:	1,2,3, OFF		
Time:	AC Hipot:	Ramp, Test:	0.1 to 999sec (± 20 ms)
	DC Hipot:	Ramp, Test:	0.1 to 999sec (± 20 ms)
	IR:	Ramp, Test:	0.1 to 999sec (± 20 ms)
	GC:	Test:	0.1 to 999sec (± 20 ms)
	LC:	Test:	0.1 to 999sec (± 20 ms)
	(Test can be set to Continuous. Ramp & Dwell can be set to OFF)		
Remote Control:	Inputs:	START, RESET Characteristics: 5/24V active low, Pulse width >1ms	
	Outputs:	PASS, FAIL, UNDER TEST Characteristics: Dry contact relay, Closed if true 120V, 100mA max	
	Connector:	9 pin male D-series & Terminal Strip	
Setup Storage:	99 Memory Groups (include 99 steps each)		
Standard Interfaces:	IEEE-488	Scanner	
Optional Interfaces:	RS232	Printer (replaces IEEE-488)	
Optional External Scanner:	Guardian 5000-01, -02, -03 and -04 Scan units		
Connectors:	Input: Binding Posts (Line & Neutral), Output: HV sockets		
Front Panel Lockout:	6 Digit Password with or without setup recall LED Display "KeyLock"		

Specifications (Continued)

General Features

Mechanical: Bench Mount (optional rack mount flanges available, G-27)
Dimensions (w x h x d): 16.875 x 5.625 x 20.50 inches
(421.875 x 140.625 x 512.50mm)

Weight: 52 lbs (24kg) net, 69 lbs (32kg) shipping

Environmental: Meets MIL-T-28800E, Type 3, Class 5
Operating: 0°C to +40°C
Storage: -20° to +70°C
Humidity: <75%
Warm-up Time: 15 minutes

Power:

• 90 - 130V AC	• 50 or 60Hz
• 200 - 250V AC	• 500W max

Supplied:

- Instruction Manual (150528)
- Calibration Certificate
- AC Power Cable
- Test Leads (S02 & G15)
- Corded Product Adapter (G30)
- Power Entry Adapter (G33)

Ordering Information:	<u>Description</u>	<u>Catalog No.</u>
	Production Safety Analyzer for Single Phase Electrical Products	Guardian 6200

Accessories

Accessories Included

Item	Quantity	QuadTech P/N
IEEE-488 (GPIB) Interface (Standard/Installed)	1	700081
AC Power Cord	1	4200-0300
Power Line Fuse 6.3A SB	1	520071
Power Line Fuse 3.15A SB	1	520072
High Voltage Lead Set, 1m with alligator clips	1	S02
Ground Continuity Test Lead Set with spring clips	1	G15
Corded Product Adaptor (115V)	1	G30
Power Entry Adaptor	1	G33
Instruction Manual	1	150528
Calibration Certificate	1	N/A

Accessories/Options Available

Item	Quantity	QuadTech P/N
High Voltage Lead Set, high & low, 1m (std. with unit)	1	S02
Foot Switch	1	S05
Power Entry Adaptor Cable, (Ground Continuity)	1	G14
Ground Continuity Lead Set (std. with unit)	1	G15
International Power Strip	1	G16
RS232 Interface	1	G26
Rack Mount Flanges	1	G27
Printer Interface (Replaces IEEE-488 Interface)	1	G28
500VA Isolation Transformer	1	G31
1000VA Isolation Transformer	1	G32
External Scanner: 8 HV Channels, Front Connection	1	5000-01
External Scanner: 8 HV Channels, Front; 4 GC Rear	1	5000-02
External Scanner: 8 HV Channels, Rear; Rack Mountable	1	5000-03
External Scanner: 8 HV Channels, Rear; 4 GC Rear; Rack Mount	1	5000-04
HV = High Voltage		
GC = Ground Continuity		

Safety Precautions

The Guardian 6200 Production Safety Analyzer can provide an output voltage as high as 6000VDC (5000VAC) to the external device under test (DUT). Although the Guardian unit is designed with full attention to operator safety, serious hazards could occur if the instrument is used improperly and these safety instructions are not followed.

1. The Guardian 6200 unit is designed to be operated with its chassis connected to earth ground. The instrument is shipped with a three-prong power cord to provide this connection to ground. This power cord should only be plugged in to a receptacle that provides earth ground. Serious injury can result if the Guardian 6200 is not connected to earth ground.
2. Tightly connect cable(s) to the (black) **Drive-** terminal. If this is not done, the DUT's casing can be charged to the high voltage test level and serious injury or electrical shock hazards could result if the DUT is touched.
3. Never touch the metal of the High Voltage probe directly. Touch only the insulated parts of the lead(s).
4. Never touch the test leads, test fixture or DUT in any manner (this includes insulation on all wires and clips) when the high voltage is applied and the red **DANGER** light is ON.
5. Before turning on the Guardian unit, make sure there is no device (DUT) or fixture connected to the test leads.
6. After each test, press the **[STOP]** (red) button for safety. This terminates the high voltage being applied to the output terminals.
7. When the red **DANGER** LED is lit or flashing, NEVER touch the device under test, the lead wires or the output terminals.
8. Before touching the test lead wires or output terminals make sure :
 - a) The red **[STOP]** button has been pressed
 - b) The red **DANGER** LED is OFF.
9. **In the case of an emergency**, turn OFF the POWER switch using a "hot stick" and disconnect the AC power cord from the wall. **DO NOT TOUCH THE Guardian 6200 INSTRUMENT.**
10. If the **DANGER** LED does not go **off** when the **[STOP]** button is pressed, immediately stop using the tester. It is possible that the output voltage is still being delivered regardless of the TEST ON/OFF control signal.
11. When the Guardian 6200 instrument is used in remote control mode, be extremely careful. The High Voltage Output is being turned on and off with an external signal.

Condensed Operating Instructions

WARNING

High Voltage is applied to the white **HV** OUTPUT terminal anytime the red **DANGER** LED is on or flashing. Always make sure the **DANGER** LED is **OFF** when connecting or disconnecting the Device Under Test (DUT).

General Information

The Guardian 6200 Production Safety Analyzer is a measuring instrument for direct readout of Hipot output voltage, insulation resistance, ground bond and line leakage current. The voltage applied to the device under test is adjustable from 50V to 5kVAC and 50V to 6kVDC. The current limit is adjustable from 1 μ A to 40mA AC in 1 μ A or 10 μ A steps and 0.1 μ A to 20mA DC in 0.1 μ A, 1 μ A or 10 μ A steps. PASS and FAIL LEDs provide a visual display of test results based on preset limits.

Start-Up

The Guardian 6200 unit can be operated from a power source between 90 and 250VAC at a power line frequency of 50 or 60Hz. The standard Guardian 6200 unit is shipped from QuadTech with a 6.3A fuse in place for AC 90-130V operation. (A 3.15A fuse is included for 200-250V operation). The G6200 unit is shipped with the line voltage selector set for 120V. Refer to paragraph 1.4.3 to change a fuse and to change the line voltage selector.

Connect the Guardian 6200 unit AC power cord to the source of proper voltage. The G6200 is designed to be operated with its chassis connected to earth ground. The unit is shipped with a three prong power cord to provide this connection to ground. This power cord should only be plugged in to a receptacle which provides earth ground. Serious injury can result if the Guardian 6200 is not connected to earth ground.

Press the [POWER] button on the front panel to apply power. To switch the power off press the [POWER] button again or if measurements are to be made proceed with Test Parameter Set-Up in Table COI-1. **Note:** the G6200 unit should warm-up for 15 minutes prior to use.

Test Parameter Set-Up

Press [PROG] and enter the Test Parameters according to your test specification. Refer to Table COI-1. For operator safety and complete instructions, read this instruction manual in full before testing.

Condensed Operating Instructions (Continued)

Table COI-1: Test Parameters

Test	Test Mode	V Test (KV)	IR HI R (MΩ) GR (mΩ)	I HI Limit (mA) I (GR)	IR LO R (MΩ) GR (mΩ)	I LO Limit (mA)	ARC Detect (mA)	Test Time (sec)	Ramp Time (sec)
AC Hipot	SET	SET		SET		SET	SET	SET	SET
DC Hipot	SET	SET		SET		SET	SET	SET	SET
Insulation Resistance	SET	SET	SET		SET			SET	SET
Ground Bond	SET	SET	SET	SET	SET			SET	
Line Leakage	SET Mode	SET Device	SET Line	SET High I limit	SET Low I limit	SET power monitor		SET time	

NOTE

Refer to paragraphs 2.3.1, 2.3.2, 2.4, 2.5, 2.6 and 2.7 for a full description of programming test parameters and instruction on how to store the test setup. Test parameters must be set **before** the G6200 unit can be zeroed.

Zeroing/Offset

After setting your test parameters, zero the Guardian 6200 unit by using the automatic offset. With no device connected, connect the appropriate cable (or other fixture) into the front (or rear) panel OUTPUT connectors, illustrations that follow are shown with connection to the front panel. Refer to paragraph 2.9 for cable connections based on tests to be made. Test leads for AC Hipot, DC Hipot and IR measurements should be OPEN and test leads for GR should be SHORTED. Disconnect the DUT from the G30 corded product adapter prior to measuring offset.

Press the [OFFSET] key once. Display reads “Offset is GET. Press Test Key”. **CAUTION:** H.V. will be applied to the test leads. Press the [TEST] key once. Display shows your test set-up. Press the [OFFSET] key once. Display shows your offset. Offset has to be recalculated each time you change your test parameters, test leads or test fixture.

Condensed Operating Instructions (Continued)

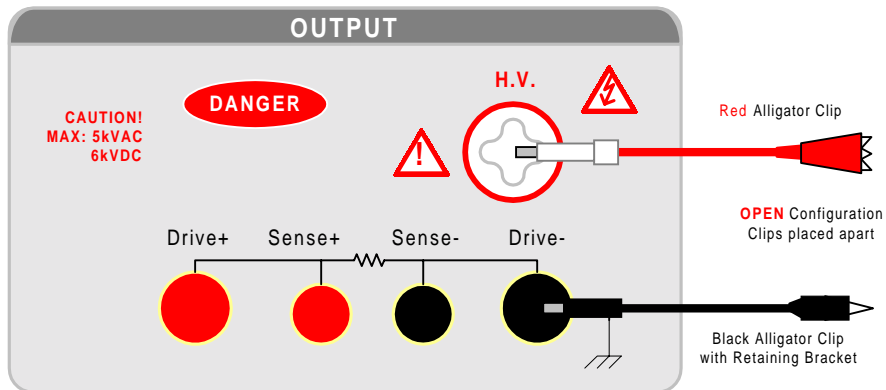

Figure COI-1: Zero/Offset OPEN Configuration
(Use for AC Hipot, DC Hipot & IR Tests)

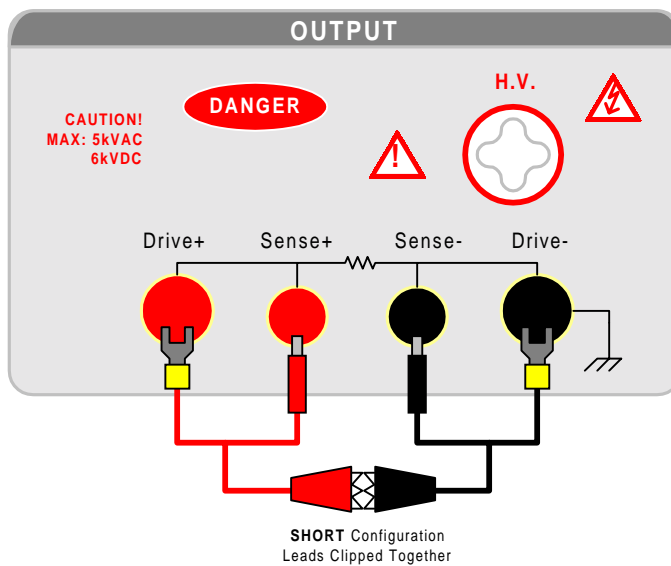

Figure COI-2: Zero/Offset SHORT Configuration
(Use for GR Test)

Condensed Operating Instructions (Continued)

Measurement Mode

The G6200 Production Safety Analyzer is capable of measuring AC Hipot, DC Hipot, Insulation Resistance, Line Leakage Current and Ground Bond. Refer to paragraph 2.9 for the appropriate cable connection to the device under test. Refer to paragraphs 2.3.1, 2.3.2, 2.4, 2.5, and 2.6 for instruction on programming a test listed above.

AC Hipot Measurement Example (using S02 Lead Set):

- 1 Turn Power ON.
- 2 Let Guardian 6200 unit warm-up 15 minutes.
- 3 Connect Black ground cable to G6200 **Drive-** terminal.
- 4 Connect Red high voltage cable to G6200 **H.V.** terminal.
- 5 Press [PROG] and enter your Test Parameters Press [PROG] again to accept it.
- 6 Zero the Guardian 6200 unit (OFFSET).
- 7 [STORE] Test Setup (If desired).
- 8 Connect Device Under Test (DUT).
- 9 Press red **[STOP]** button.
- 10 Press green **[TEST]** button.
- 11 Record Readings.
- 12 Press red **[STOP]** button.

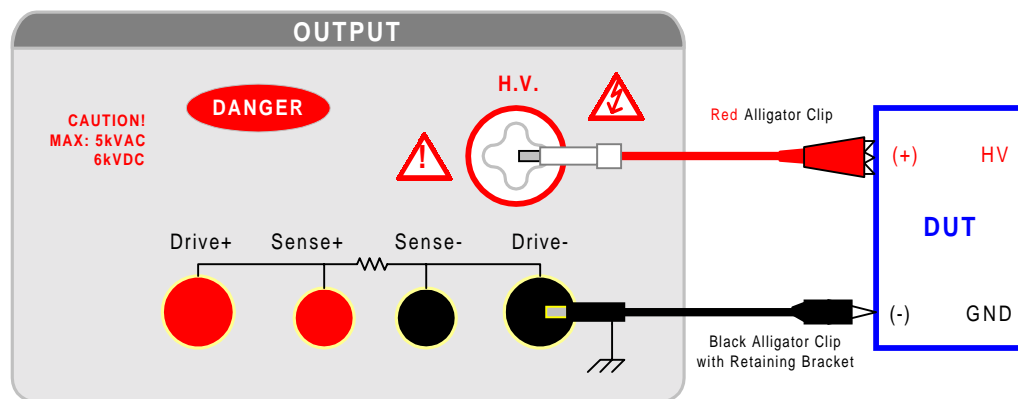

Figure COI-3: S02 Cable Connection To Device Under Test

NOTE

If using the 6000-04 connected to the G30 Corded Product Adaptor to hipot a product, select High = 1 (Scan Box-Channel 1) so that the scanner receives the high voltage test level.

If "High = Disable" is selected, the scanner receives no voltage output.

Section 1 : Introduction

1.1 Unpacking and Inspection

Inspect the shipping carton before opening. If damaged contact the carrier agent immediately. Inspect the Guardian 6200 instrument for any damage. If the instrument appears damaged or fails to meet specifications notify QuadTech (refer to instruction manual front cover) or its local representative. Retain the shipping carton and packing material for future use such as returning for recalibration or service.

1.2 Product Overview

The Guardian 6200 Production Safety Analyzer is designed for fast easy production testing of single phase electronic devices, appliances and instruments. Without changing the connection to the DUT, the G6200 instrument is able to perform five critical safety tests on a single device: **AC hipot, DC hipot, insulation resistance, line leakage current and high current ground bond measurements**. The hipot test can be programmed over a voltage range of 0.05 to 5kV AC and 0.05 to 6kV DC with a min/max leakage current detection range of 1 μ A to 40mA AC and 0.1 μ A to 20mA DC. Insulation resistance measurements are possible to 50G Ω at programmable DC test voltages between 50 and 1000V. A ground bond test to 30A AC is also possible. True earth line leakage measurement is possible for five human body simulation circuits per UL544NP, UL544P, UL1563, UL2601-1, IEC601-1, UL-1950, UL3101-1 and IEC 950 test standards. The instrument comes standard with internal storage of up to 99 memory groups and an IEEE-488 interface for remote control operation and communication with other instrumentation.

WARNING

The Guardian 6200 Production Safety Analyzer is capable of generating extremely HIGH VOLTAGE up to 6000VDC.

Do NOT touch the Test Terminals when the red DANGER LED is ON.

Always make sure the DANGER LED is OFF when connecting or disconnecting the device under test (DUT)

1.3 Controls and Indicators

1.3.1 Front Panel Controls and Indicators

Figure 1-1 illustrates the controls and indicators on the front panel of the Guardian 6200 instrument. Figure 1-2 provides a detailed illustration of the key pad (4a-y of Figure 1-1). Table 1-1 identifies the controls and indicators with descriptions and functions.

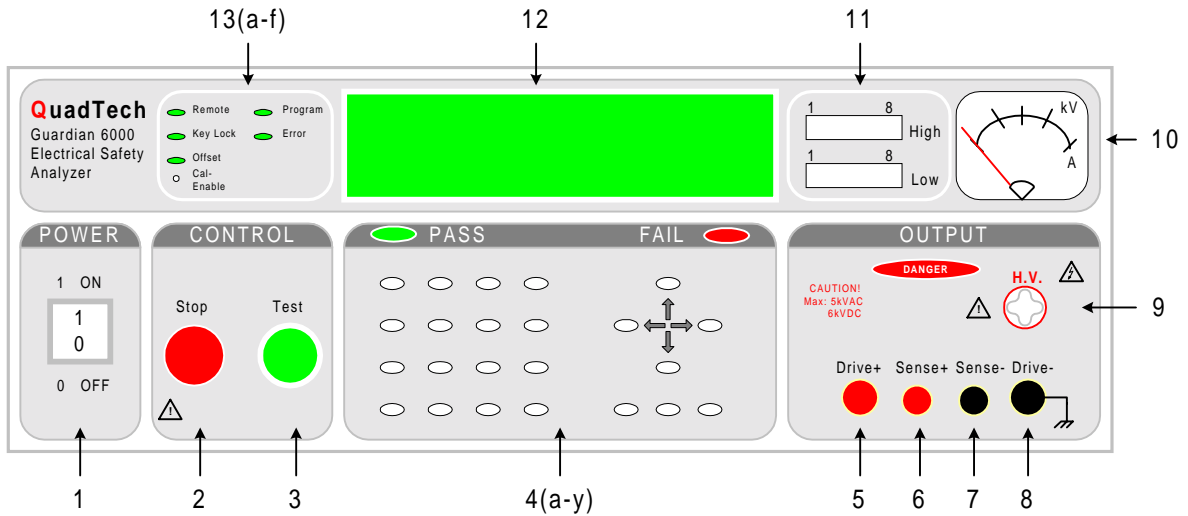
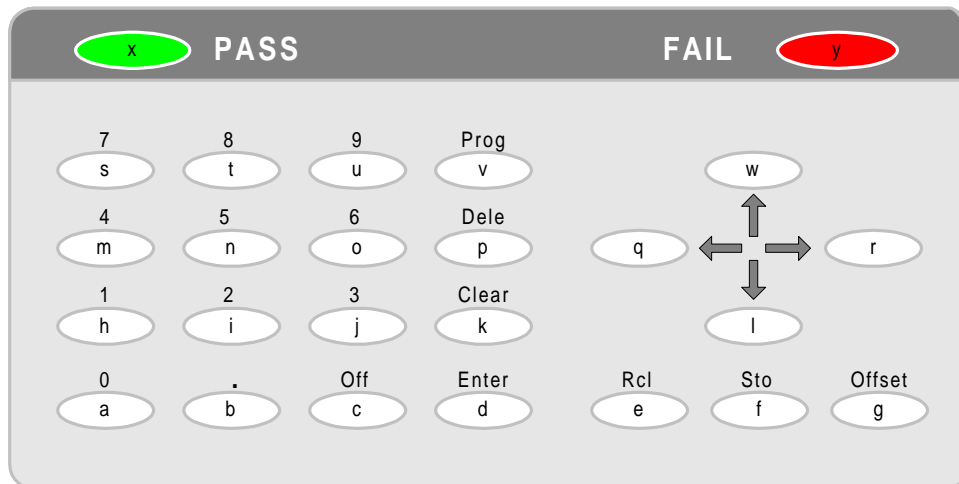

Figure 1-1: G6200 Front Panel Controls & Indicators



NOTE: The lower case letters inside the white buttons are for identification purposes only. They do **NOT**

Figure 1-2: Close-Up G6200 Key Pad (4a-y)

Table 1-1: G6200 Front Panel Controls and Indicators

Reference Number Fig 1-1& 1-2	Name	Type	Function
1	POWER	White Toggle Switch	Applies AC power to unit, 0=OFF, 1=ON
2	Stop	Red Push Button	Stops the test in progress. Reset function : Stop MUST be pressed before green Test button.
3	Test	Green Push Button	Starts a test and applies high voltage to the Test Terminals.
4	Key Pad	White Push Buttons	To program test information.
4a	0	White P-B	Numerical key
4b	.	White P-B	Decimal key
4c	Off	White P-B	Turn test parameters OFF (limits, arc)
4d	Enter	White P-B	To enter test parameters
4e	Rcl	White P-B	To recall stored test parameters (1-99) from memory
4f	Sto	White P-B	To store test parameters (1-99) from memory
4g	Offset	White P-B	To initiate zeroing (offset) function
4h	1	White P-B	Numerical key
4i	2	White P-B	Numerical key
4j	3	White P-B	Numerical key
4k	Clear	White P-B	To cancel parameter number and input again
4l	↓	White P-B	To examine steps 1-99, To ↓ test voltage, To change status
4m	4	White P-B	Numerical key
4n	5	White P-B	Numerical key
4o	6	White P-B	Numerical key
4p	Dele	White P-B	To delete a test step, those below move up
4q	←	White P-B	Under PROG, To select parameter for programming
4r	→	White P-B	Under PROG, To select parameter for programming
4s	7	White P-B	Numerical key
4t	8	White P-B	Numerical key
4u	9	White P-B	Numerical key
4v	Prog	White P-B	To enter and exit parameter setting status
4w	↑	White P-B	To examine steps 1-99, To ↑ test voltage, To change status
4x	PASS	Green LED	When lit, indicates PASS result of programmed test
4y	FAIL	Red LED	When lit, indicates FAIL result of programmed test
5	Drive+	Red Female Recptacle	High Current Terminal (Driver) for Ground Bond Test
6	Sense+	Red Female Recptacle	High Voltage Terminal (Sense) for Ground Bond Test
7	Sense-	Black Female Recptacle	Low Voltage Terminal (Sense) for Ground Bond Test
8	Drive-	Black Female Receptacle	Ground Reference for ALL Tests
9	H.V.	White Female Receptacle	High Voltage Output Terminal (Hipot, IR & Leakage Curr.)
10	Meter	Analog KV, A units	Indicates output voltage and current
11	Scanner	Two bars of 8 LEDs each	Indicate which scanner outputs are High or Low
12	Display		Indicates step, mode, limits, test setup, test result
13a	Remote	Green LED	When lit indicates Remote test being performed
13b	Key Lock	Green LED	When lit, indicates the key pad is locked out
13c	Offset	Green LED	When lit, indicates Offset is ON
13d	Program	Green LED	When lit, indicates Program function enabled
13e	Error	Green LED	When lit, indicates Error in entering test information
13f	Cal Enable	Pin sized hole	Used by Qualified Service Personnel for unit calibration

1.3.2 Rear Panel Controls and Indicators

Figure 1-3 illustrates the controls and indicators on the rear panel of the Guardian 6200 instrument. Figure 1-4 provides a detailed illustration of the voltage selector switches and relay strips on the rear panel of the Guardian 6200. Table 1-2 identifies them with description and function.

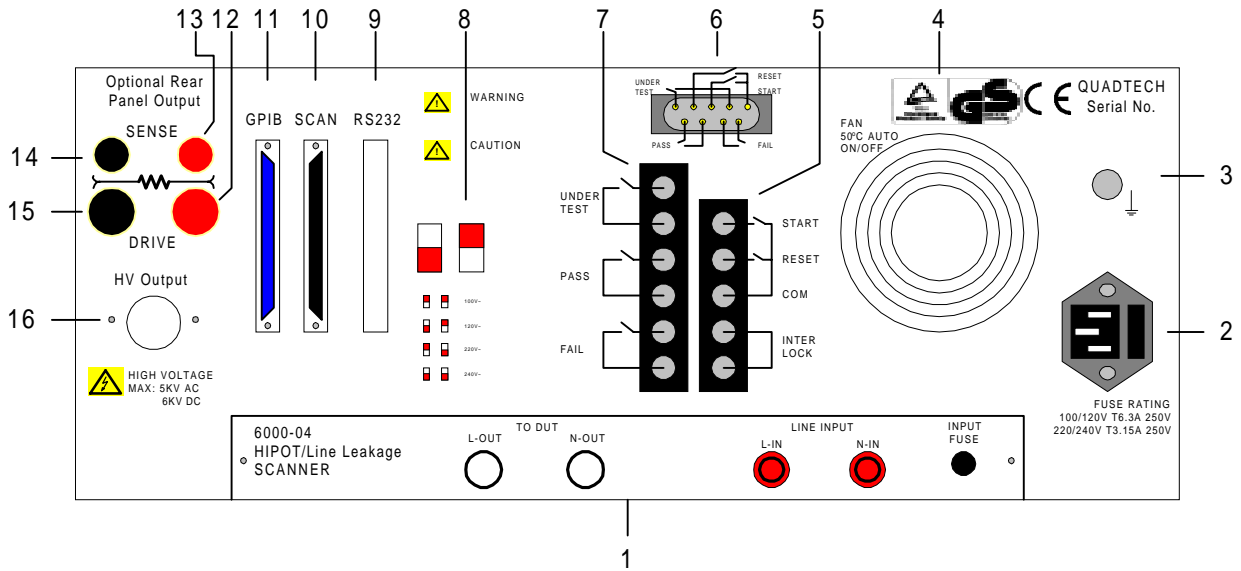

Figure 1-3: G6200 Rear Panel Controls and Connectors

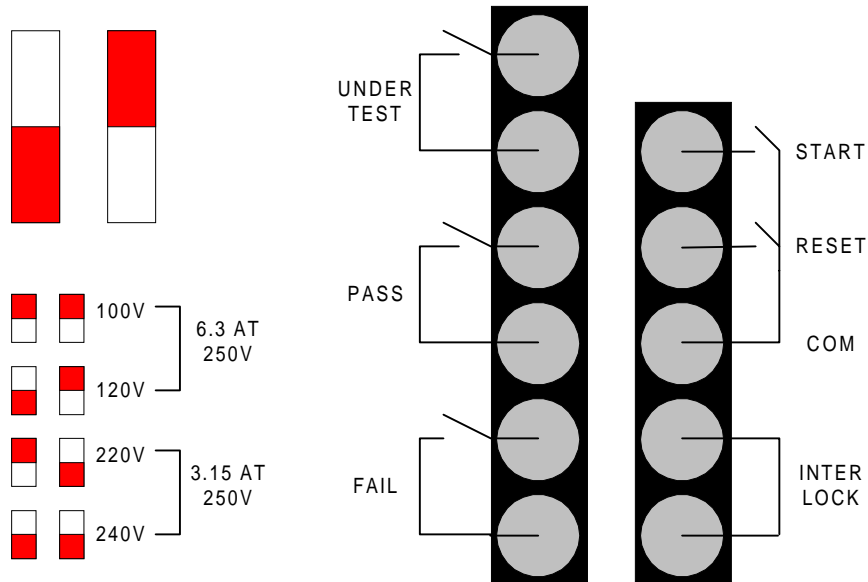

Figure 1-4: Close-Up G6200 Voltage Selector & Relay Strips

Table 1-2: G6200 Rear Panel Connectors and Controls

Reference Number Fig. 1-3	Name	Type	Function
1	6000-04	2 White HV Receptacles 2 Red Banana Plugs 1 black screw cap fuse holder	Outputs to DUT: L-OUT, N-OUT Line Inputs: L-IN, N-IN Input Fuse: 10A 250V
2	AC Inlet Module	Black 3-prong receptacle and fuse drawer	Fuse drawer and 3-wire connection for AC power Source. 6.3A 250V 100-120 operation, 3.15A 250V 220-240 operation.
3	GROUND	Silver screw	Chassis ground connection
4	FAN	Temp Control Fan	To cool unit : ON $\geq 50^{\circ}\text{C}$, OFF $< 50^{\circ}\text{C}$
5	REMOTE INPUT	Black 5 screw relay strip	Remote input signals : START, RESET, COM & INTER LOCK
6	REMOTE	Silver 9 pin D-Type Connector	Remote control connections
7	REMOTE OUTPUT	Black 6 screw relay strip	Remote output signals : UNDER TEST, PASS, & FAIL
8	Voltage Selector	Red 2-position DIP Switches (2)	Switches for selecting range of AC power source: Set to 100V for 90-100VAC operation Set to 120V for 110-130VAC operation Set to 220V for 200-220VAC operation Set to 240V for 220-250 VAC operation
9	RS232	Black 25 pin D-Type Connector	Input/Output connections for RS232 Interface
10	SCAN	Black 25 pin D-Type Connector	Input/Output connections for Scanner Interface
11	GPIB	Blue 24 pin connector	Input/Output connections for IEEE-488 Interface
12	DRIVE +	Red Female Receptacle	Optional Rear Panel Output High Current GB Test
13	SENSE +	Red Female Receptacle	Optional Rear Panel Output High Voltage GB Test
14	SENSE -	Black Female Receptacle	Optional Rear Panel Output Low Voltage GB Test
15	DRIVE -	Black Female Receptacle	Optional Rear Panel Output Ground Ref. for all Tests
16	HV OUTPUT	White Female Receptacle	Optional Rear Panel Output High Voltage Output for Hipot & IR Tests

1.4 Installation

1.4.1 Dimensions

The Guardian 6200 instrument is supplied in bench configuration (a cabinet with resilient feet for placement on a table). Flip feet are provided under the front feet so that the unit can be tilted back for convenient operator viewing.

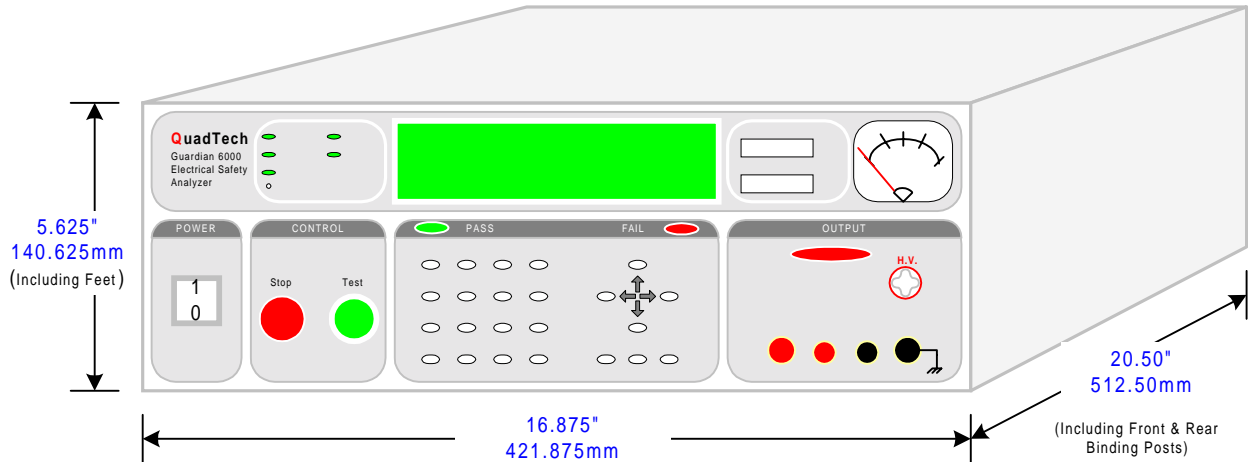



Figure 1-5: G6200 Instrument Dimensions

1.4.2 Instrument Positioning

The Guardian 6200 Production Safety Analyzer contains a digital display and an analog meter for direct readout of the measured parameters. The optimum viewing angle is slightly down and about 10° either side of center. For bench operation the front flip feet should always be used to angle the instrument up. In bench or rack mount applications the instrument should be positioned with consideration for ample air flow around the rear panel fan ventilation hole. An open space of at least 3 inches (75mm) is recommended behind the rear panel.

1.4.3 Power Requirements

 The Guardian 6200 can be operated from a power source of 90 to 130 VAC or 200 to 250 VAC. Power connection is via the rear panel through a standard receptacle. Before connecting the 3-wire power cord between the unit and AC power source make sure the voltage selection switches on the rear panel (Figure 1-4) and fuses are in accordance with the power source being used. 6.3A, 250V, 5x20mm, for 90-130V source and 3.15A, 250V, 5x20mm, for 200-250V source. Always use an outlet which has a properly connected protection ground.

Procedure for Changing A Guardian 6200 Fuse

WARNING
MAKE SURE THE UNIT HAS BEEN DISCONNECTED FROM ITS AC POWER SOURCE FOR AT LEAST 5 MINUTES BEFORE PROCEEDING.

Remove the fuse drawer, by inserting a flat head screwdriver behind the small tab located just below the 3 prong receptacle, and gently force outward.

Once the fuse drawer has been removed from the instrument snap the fuse from the holder and replace. Make sure the new fuse is of the proper rating. Note that the fuse drawer can also be used to store a spare fuse.

Install the fuse drawer back in the inlet module (fuse down) by pushing in until it locks securely in place.

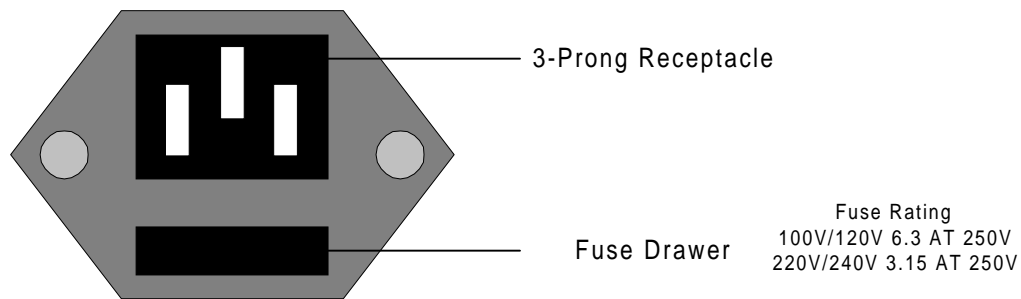

Figure 1-6 : G6200 Fuse Drawer

The Guardian 6200 also has an input fuse for the 6000-04 Line Leakage Scanner. The 10A 250V Input Fuse resides in a black screw cap holder located on the 6000-04 Line Leakage Scanner on the rear panel of Guardian 6200 instrument.

- Make sure the power switch is OFF and the power cord is disconnected from the unit and the AC power source.
- Inspect if the fuse is functional by measuring resistance ($< 15\Omega$) with an ohmmeter.
- Using a flat head screwdriver, turn the screwcap about 60° counterclockwise. The screwcap should protrude about 3.0 cm from the socket.
- Remove screwcap. Replace with new fuse.
- Replace screw cap in Guardian unit and turn the screwcap about 60° clockwise.

1.4.4 Safety Inspection



Before operating the instrument inspect the power inlet module on the rear of the Guardian 6200 to ensure that **the properly rated fuse is in place**, otherwise damage to the unit is possible. Refer to paragraph 1.4.3.

The Guardian 6200 is shipped from QuadTech with a standard U.S. power cord, QuadTech P/N 4200-0300(with Belden SPH-386 socket or equivalent and 3-wire plug conforming to IEC 320). Make sure that the instrument is used only with these cables (or approved international cord set) to ensure that the instrument is provided with **connection to protective earth ground**.

The surrounding environment should be free from excessive dust to prevent contamination of electronic circuits. The surrounding environment should also be free from excessive vibration. Do not expose the Guardian 6200 unit to direct sunlight, extreme temperature or humidity variations, or corrosive chemicals.

Section 2 : Operation

2.1 Terms and Conventions

Table 2-1: Measurement Unit Prefixes

<u>Multiple</u>	<u>Scientific</u>	<u>Engineering</u>	<u>Symbol</u>
1000000000000000	10 ¹⁵	Peta	P
100000000000000	10 ¹²	Tera	T
10000000000	10 ⁹	Giga	G
1000000	10 ⁶	Mega	M
1000	10 ³	Kilo	k
.001	10 ⁻³	milli	m
.000001	10 ⁻⁶	micro	u
.000000001	10 ⁻⁹	nano	n
.0000000000001	10 ⁻¹²	pico	p
.000000000000001	10 ⁻¹⁵	femto	f

ARcing: Sparking or ‘flashing over’ caused by a breakdown of electrical insulation.

Current:

AC: Alternating Current. An electric current that has one polarity during part of the cycle and the opposing polarity during the other part of the cycle. Residential electricity is AC.

DC: Direct Current. Non-reversing polarity. The movement of charge is in one direction. Used to describe both current and voltage. Batteries supply direct current (DC).

Charging Current: An insulated product exhibits the basic characteristics of a capacitor. Application of a voltage across the insulation causes a current to flow as the capacitor charges. This current instantaneously rises to a high value as voltage is applied then exponentially decays to zero as the DUT becomes fully charged. Charging current decays to zero much faster than dielectric absorption.

Dielectric Absorption:	The physical phenomenon in which insulation appears to absorb and retain an electrical charge slowly over time. Apply a voltage to a capacitor for an extended period of time, then quickly discharge it to zero voltage. Leave the capacitor open circuited for a period of time then connect a voltmeter to it and measure the residual voltage. The residual voltage is caused by the dielectric absorption of the capacitor.
Dielectric Strength:	The ratio between the voltage at which breakdown of the insulating material occurs and the distance between the two points subject to the applied voltage.
Dielectric Withstand Test:	This is the most common electrical safety test performed. A high voltage (either AC or DC) is applied to determine if a breakdown will occur in the insulation of the DUT. Dielectric Withstand is also referred to as a hipot (high potential) test.
Discharge:	The act of draining off an electrical charge to ground. Devices that retain charge should be discharged after an IR test or a DC hipot test.
DUT:	Device Under Test. The product being tested.
Frequency:	The rate at which current or voltage reverses polarity and then back again completing a full cycle, measured in Hertz (Hz) or cycles/second. AC Line Frequency = 50/60 Hz.
Ground:	
Ground:	The base reference from which voltages are measured, nominally the same potential as the earth. Also the side of a circuit that is at the same potential as the base reference.
Ground Bond Test:	Test to verify that all conductive parts of a product that are exposed to user contact are connected to the power line ground. The ground bond test is similar to the ground continuity test. The main difference is that the ground bond test verifies the integrity of the ground connection using a high current AC signal with current level as high as 30Amps. Ground bond provides a better simulation of how a product will perform under an actual fault condition.

Ground Continuity: Test to verify that all conductive parts of a product that exposed to user contact are connected to the power line ground. A GC test uses a low current DC signal to ensure the ground connection has a resistance of $<1\Omega$.

Insulation Resistance: The total resistance between any two points separated by electrical insulation. The IR test determines how effective the dielectric (insulation) is in resisting the flow of current.

Interface:

IEEE-488: General Purpose Interface Bus (GPIB). An industry standard definition of a Parallel bus connection for the purpose of communicating data between devices.

RS232: An industry standard definition for a Serial line communication link or port.

Scanner: A electronic device designed to switch or matrix signals.

Leakage Current (LC):

Leakage Current: The residual flow of current that flows through the insulation after a high voltage has been applied for a period of time. The leakage current is equal to the applied voltage divided by the insulation resistance. Leakage current is the main measured value for AC hipot and DC hipot.

Applied Part LC Test: A line leakage current test which measures the current that would flow from, to or between applied parts such as sensor and patient leads.

Earth LC : The leakage current from all earthed parts of the product. The current flowing from the mains supply through or across insulation into the protective earth (PE) conductor.

Enclosure LC : Leakage from the enclosure or other parts, excluding applied parts that are not connected to a protective earth (PE) conductor. Also known as Touch/Chassis Leakage.

Patient LC: The current flowing from every individual part of the applied part back to earth or the current flowing from an unintended appearance of a voltage on the patient back to an F-Type Applied Part.

Patient Auxiliary LC: Current flowing between patient connections and that is not intended to be there to produce an effect in the patient.

Limits:

- High Limit:** The high limit is the upper value for a test to be considered a pass. If the measured value is higher than the high limit the test is considered a fail. In hipot, leakage current and ground bond test modes a high limit is required.
- Low Limit:** The low limit is the lower value for a test to be considered a pass. If the measured value is lower than the low limit the test is considered a fail. This limit is typically used for AC Hipot to ensure the DUT is connected. In insulation resistance test mode a low limit is required.
- Mode:** The test which is to be performed such as AC Hipot (WAC), DC Hipot (WDC), Insulation Resistance (IR), Ground Bond (GR) or Leakage Current (LC).
- RAMPing:** The gradual increase or decrease of voltage or current over a period of time (step).
- Step:** The Guardian 6200 can perform up to 99 tests in a sequence. The step number indicates in which order the tests will be performed. For example if step 1 is a ground bond test, step 2 an AC hipot and step 3 an insulation resistance measurement then when a test is started the Guardian 6200 will perform a ground bond test followed by an AC hipot then an insulation resistance measurement.

2.2 Startup

Check to make sure the Red Voltage Selector Switches on the rear panel agree with the power source available. Depending on the power source the switch positions should be in the up or down positions as shown in Figure 1-4 (Close-Up of G6200 Rear Panel).

WARNING

NEVER TOUCH THE TEST LEADS IN ANY MANNER (this includes insulation on all wires and clips) when **HIGH VOLTAGE IS APPLIED** and red **DANGER** LED is **ON**.

USE ALL PRECAUTIONS NECESSARY TO **AVOID TOUCHING THE DEVICE UNDER TEST** WHEN THE RED **DANGER** LED IS ON OR FLASHING.

Connect the instrument power cord to the source of proper voltage. **The instrument is to be used only with three wire grounded outlets.**

Power is applied to the Guardian 6200 instrument by pressing the beige [POWER] toggle switch on the front panel to ON (1 position). The Guardian 6200 unit should have a warm-up time of at least 15 minutes prior to use.

WARNING

DO NOT TURN INSTRUMENT POWER ON OR OFF WITH TEST DEVICES CONNECTED.

Operation with External Scanner

If the 6200 instrument is connected to an external scanner, then the scanner channels must be programmed for an AC hipot, DC hipot, insulation resistance or ground bond test. When an external scanner is connected to the G6200 instrument, two additional display screens appear during programming. Refer to Figure 2-1. Use the numerical keypad to enter which channel or channels have HV (High) or GROUND (Low) applied during the test. If “disable” is selected, the scanner will not be used. The instruction “Select Scanner Disable” prompts the user to define which of the 8 scanner channels are high or low per scan box. The internal scanner (6000-04 Line Leakage Scanner) is defined as Scan Box 1. Scan Box 2 is the first external scanner. Scan Box 3 is the second external scanner. Up to 7 external scanners can be added for a total of 64 channels. Refer to paragraph 3.3 for external scanner programming.

High =Disable
Scan Box-Channel 1

Low = Disable
Scan Box-Channel 1

Figure 2-1: Scanner Programming Display

2.3 Programming Hipot Tests

The Guardian 6200 Production Safety Analyzer is capable of performing the tests listed in Table 2-2. A single step test can be performed on any device and is programmed as described in paragraphs 2.3.1-2.6. When the device under test requires a multi-step test, the order of test precedence is very important. When the Guardian 6000-04 Line Leakage Scanner is installed in the rear panel, program a Ground Bond (GR) test then a Hipot (WAC/WDC) or Insulation Resistance (IR) test, then lastly an Earth Line Leakage Current (LC) test. This assures there is no short present prior to the LC test. Refer to paragraph 2.7 for instructions on programming a multi-step test. A test may consist of up to 99 steps.

Table 2-2: Guardian 6200 Electrical Safety Tests

Test	Instrument Symbol	Programming Instructions Paragraph	Test (Step) Order for Multi-Step Test
AC Hipot	WAC	2.3.1	2
DC Hipot	WDC	2.3.2	2
Insulation Resistance	IR	2.4	2
Ground Bond	GR	2.5	1
Earth Line Leakage Current	LC	2.6	3
Pause		2.7	3

NOTE

If using the 6000-04 connected to the G30 Corded Product Adaptor to hipot a product, select High = 1 (Scan Box-Channel 1) so that the scanner receives the high voltage test level.

If “High = Disable” is selected, the scanner receives no voltage output.

2.3.1 Programming an AC Hipot Test

Press [PROG]		Select Step = 1 1-99 (UP/DOWN)
Select Test Step	Press UP or DOWN arrow key to enter test step	
Press [ENTER]		Select Mode = WAC Press UP/DOWN
Select Test MODE	Press UP arrow key to display WAC	
Press [ENTER]		High =1 Box-1 Channel 1
Select Internal Scanner to High*	Press Numerical keys to enter high scanner channels	
Press [ENTER]		Low = Disable Box-1 Channel 1
Select Scanner Disable	Press Numerical keys to enter low scanner channels	
Press [ENTER]		Voltage = 0.000KV 0.05-5KV
Select Test Voltage (KV)	Press Numerical & Decimal keys to enter test voltage	
Press [ENTER]		High Limit = 0.500mA 0.001-40mA
Select High Limit (mA)	Press Numerical & Decimal keys to enter high current limit	
Press [ENTER]		Low Limit = Disable 0-40mA 0 = Disable
Select Low Limit (mA)	Press Numerical & Decimal keys to enter low current limit	
Press [ENTER]		ARC Limit = Disable 0-40mA 0 = Disable
Select ARC Limit (mA)	Press Numerical & Decimal keys to enter ARC limit	
Press [ENTER]		Test Time = _10.0s 0-999 s 0 = Disable
Select Test Time (sec)	Press Numerical & Decimal keys to enter Test Time	
Press [ENTER]		Ramp Time = Disable 0-999 s 0 = Disable
Select Ramp Time (sec)	Press Numerical & Decimal keys to enter Ramp Time	
Press [ENTER]		Select Step = 2 1-99 (UP/DOWN)
Press [PROG]		Step-01 10.0s 1.200KV WAC 0.500mA

* If using G30 and/or G33.

2.3.2 Programming a DC Hipot Test

Press [PROG]		Select Step = 1 1-99 (UP/DOWN)
Select Test Step	Press UP or DOWN arrow key to enter test step	
Press [ENTER]		Select Mode = WDC Press UP/DOWN
Select Test MODE	Press UP arrow key to display WDC	
Press [ENTER]		High =1 Box-1 Channel 1
Select Internal Scanner to High*	Press Numerical keys to enter high scanner channels	
Press [ENTER]		Low = Disable Box-1 Channel 1
Select Scanner Disable	Press Numerical keys to enter low scanner channels	
Press [ENTER]		Voltage = 0.000KV 0.05-6KV
Select Test Voltage (KV)	Press Numerical & Decimal keys to enter test voltage	
Press [ENTER]		High Limit = 0.500mA 0.0001-20mA
Select High Limit (mA)	Press Numerical & Decimal keys to enter high current limit	
Press [ENTER]		Low Limit = Disable 0-20mA 0 = Disable
Select Low Limit (mA)	Press Numerical & Decimal keys to enter low current limit	
Press [ENTER]		ARC Limit = Disable 0-20mA 0 = Disable
Select ARC Limit (mA)	Press Numerical & Decimal keys to enter ARC limit	
Press [ENTER]		Test Time = _10.0s 0-999 s 0 = Disable
Select Test Time (sec)	Press Numerical & Decimal keys to enter Test Time	
Press [ENTER]		Ramp Time = Disable 0-999 s 0 = Disable
Select Ramp Time (sec)	Press Numerical & Decimal keys to enter Ramp Time	
Press [ENTER]		Select Step = 3 1-99 (UP/DOWN)
Press [PROG]		Step-01 10.0s 1.200KV WDC 0.500mA

* If using G30 and/or G33.

2.4 Programming an Insulation Resistance Test

Press [PROG]		Select Step = 1 1-99 (UP/DOWN)
Select Test Step	Press UP or DOWN arrow key to enter test step	
Press [ENTER]		Select Mode = IR Press UP/DOWN
Select Test MODE	Press UP arrow key to display IR	
Press [ENTER]		High =Disable Box-1 Channel 1
Select Scanner Disable*	Press Numerical keys to enter high scanner channels	
Press [ENTER]		Low = Disable Box-1 Channel 1
Select Scanner Disable*	Press Numerical key to enter low scanner channels	
Press [ENTER]		Voltage = 0.000KV 0.05-1 KV
Select Test Voltage (KV)	Press Numerical & Decimal keys to enter test voltage	
Press [ENTER]		Low Limit = _ 1.0M Ω 0.1-50000 M Ω
Select Low Limit (M Ω)	Press Numerical & Decimal keys to enter low resistance limit	
Press [ENTER]		High Limit = Disable 0-5000 M Ω 0 = Disable
Select High Limit (M Ω)	Press Numerical & Decimal keys to enter high resistance limit	
Press [ENTER]		Test Time = _10.0s 0-999 s 0 = Disable
Select Test Time (sec)	Press Numerical & Decimal keys to enter Test Time	
		Ramp Time = Disable 0-999 s 0 = Disable
Select Ramp Time (sec)	Press Numerical & Decimal keys to enter Ramp Time	
Press [ENTER]		Select Step = 3 1-99 (UP/DOWN)
Press [PROG]		Step-01 10.0s 1.000KV IR 1.0M Ω

*** If not using internal/external scanner(s).**

2.5 Programming a Ground Bond Test

Press [PROG]		Select Step = 1 1-99 (UP/DOWN)
Select Test Step	Press UP or DOWN arrow key to enter test step	
Press [ENTER]		Select Mode = GR Press UP/DOWN
Select Test MODE	Press UP arrow key to display GR	
Press [ENTER]		High = Disable Box – 2 Channel 1
Select Scanner Disable*	Press Numerical keys to enter high scanner channels	
Press [ENTER]		Current = _0.00A 1-30A
Select Current	Press Numerical keys to enter current in (A)	
Press [ENTER]		High Limit = 100.0mΩ 0.1-510mΩ
Select High Limit (mΩ). Press Numerical & Decimal keys to enter high limit in (mΩ)		
Press [ENTER]		Low Limit = Disable 0.1-510mΩ 0=Disable
Select Low Limit (mΩ). Press Numerical & Decimal keys to enter low limit in (mΩ)		
Press [ENTER]		Test Time = _10.0s 0-999s 0=Disable
Select Test Time (sec). Press Numerical & Decimal keys to enter Test Time in (sec)		
Press [ENTER]		Select Step = 4 1-99 (UP/DOWN)
Press [PROG]		Step-01 10.0s 1.00A GR 100.0mΩ

* Applicable if external scanner is not being used. Reference ¶ 2.2 and 3.5.

2.6 Programming an Earth Line Leakage Current Test

2.6.1 Leakage Current Test Conditions

Each specific Electrical Safety Testing Standard has its own particular test conditions. In general, the minimal test conditions specified for a Leakage Current (LC) test are Fault, Line Voltage/Frequency and Measurement Equipment. Electrical Safety Testing Standard IEC60601-1 is used as reference in this discussion of Earth Leakage Current tests.

2.6.1.1 Faults

Leakage Current tests are performed under certain conditions to simulate all electrical operation possibilities that may occur in the product's use. SINGLE faults are product specific problem conditions that could occur. NORMAL faults are electrical line specific conditions that could normally occur on a daily basis. Normal faults are not considered a product problem. The Guardian 6200 is capable of testing the Fault Conditions listed in Table 2-2.

Table 2-2: Guardian 6200 Leakage Current Fault Conditions

Test Mode	Fault Condition	Ground Connection
0	Normal	Open
1	Reverse	Open
2	Single Fault Normal	Open
3	Single Fault Reverse	Open

2.6.1.2 Line Voltage/Frequency

The line voltage and frequency should be considered when performing a Leakage Current (LC) test. It is important to do the worst-case testing of the product to ensure operator and patient safety. The worst case is generally 240VAC at 50Hz for a product used worldwide. The worst case is 120VAC at 60Hz for a product used solely in the United States. The IEC60601-1 standard requires that the product be assessed at 10% above these worst case levels for safety testing.

2.6.1.3 Measurement Equipment

An important consideration in line leakage testing is the actual measurement device used. Safety Standards require the use of a true RMS multi-meter with a very specific load. The load simulates the impedance of the human body. Figure 2-2 illustrates an example required test load.

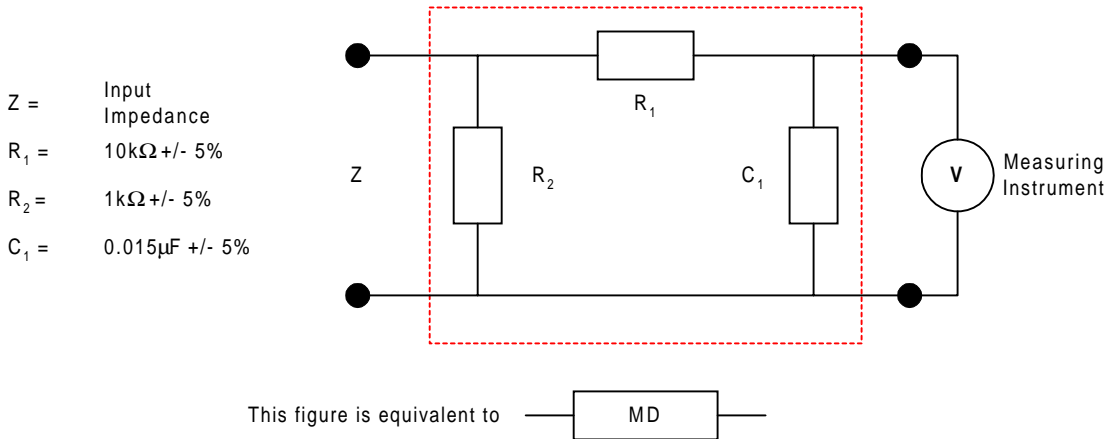

Figure 2-2: Required Test Load

Each Product Safety Standard has a specific circuit that models the impedance of the human body as illustrated in Figure 2-3.

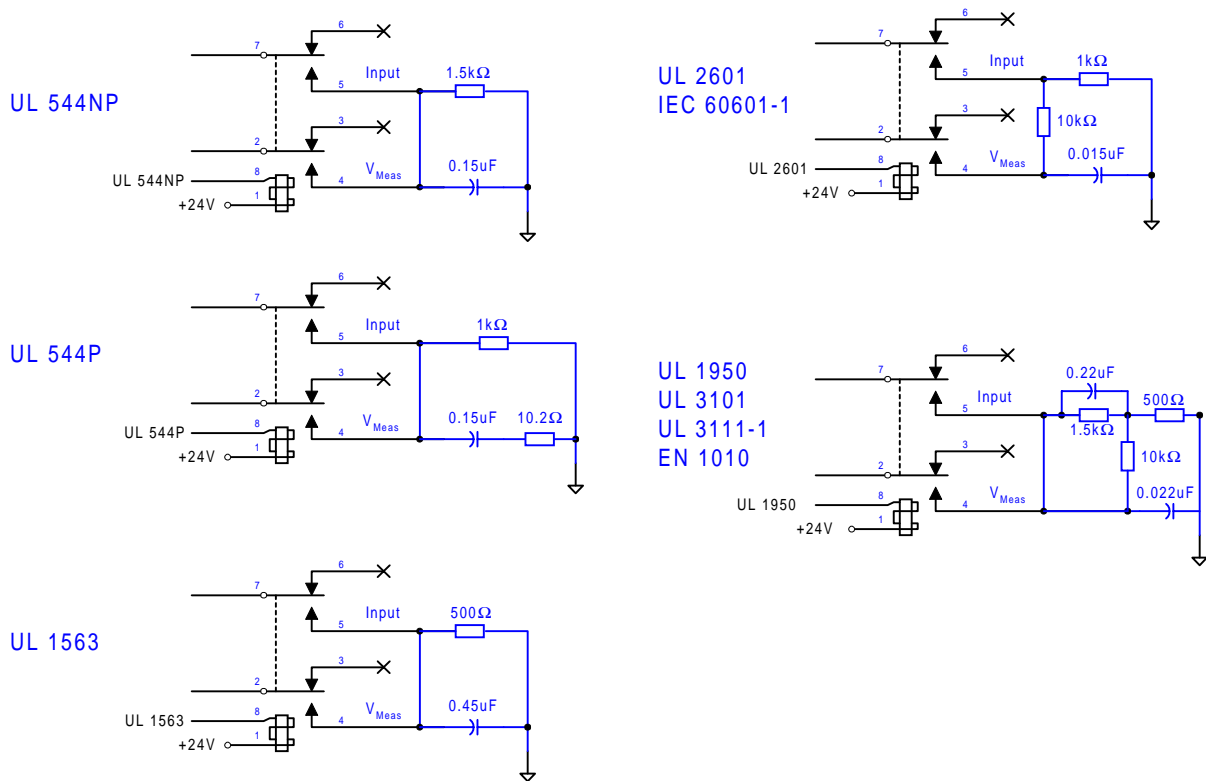

Figure 2-3: Circuit Models for Impedance of Human Body

2.6.2 G6200 LC Test Parameters

The Guardian 6200 Production Safety Analyzer measures Earth Line Leakage Current. The instrument simulates the human body models listed in Table 2-3. The test modes and other Earth LC parameters are also listed in Table 2-3. The Earth LC Test is the sum of all leakages of current in the DUT (device under test). The test measures the current flowing back to Earth Ground through the ground conductor of the line (power) cord.

Table 2-3: G6200 LC Test Parameters

Parameter	Range				
Human Body Model	1: UL544NP	2: UL544P	3: UL1563	4: UL2601-1, IEC601-1	5: UL1950, UL3101-1, IEC950
Test Mode	0: Normal	1: Reverse	2: Single Fault Normal	3: Single Fault Reverse	
High LC Limit	.0001– 9.999mA*				
Low LC Limit	OFF or	.0001-9.999mA*			
DUT Power Monitor	1: Voltage	2: Current	3: Power (V•A)		
High Limit	0 – 300V	0 – 10A	0 – 2200VA		
Low Limit	0 – High limit	0 – High limit	0 – High limit		
Test Time	OFF or	1 – 999.0sec.			

* Note: For UL544NP, the limits are: 0.0001 to 6.000mA.

2.6.2.1 G6200 Connection to DUT

The Guardian 6200 instrument includes a Guardian 6000-04 Scanner which will measure the ‘true’ Earth Line leakage of the DUT. The 6000-04 scanner requires the use of an isolation transformer for proper operation. For a ‘true’ line leakage test, connect the DUT to the Guardian 6200 rear panel output terminals as shown in Figure 2-4.

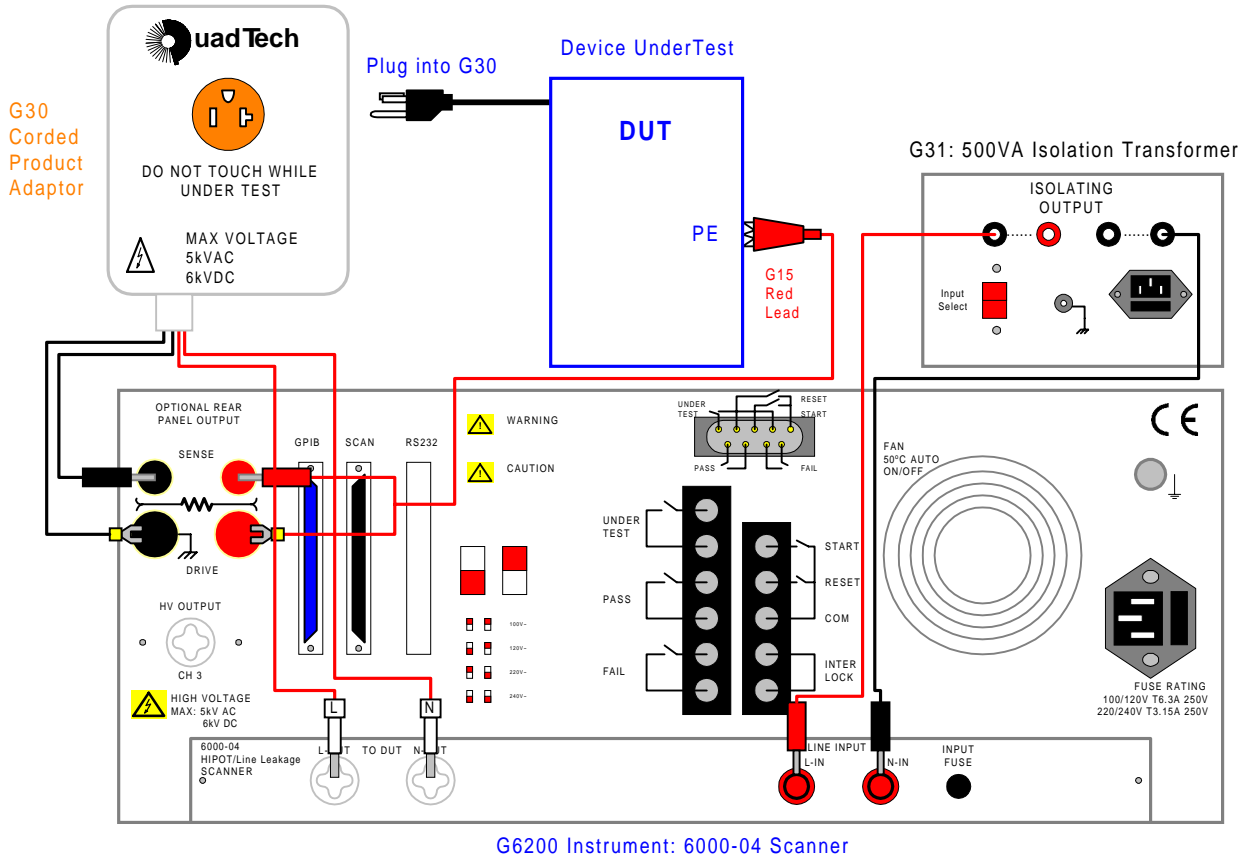

Figure 2-4: Connection of DUT to 6000-04 for Line Leakage Test

2.6.2.2 Earth LC Programming Instructions:

Press [BUTTON]:

[PROG]

Select Test Step

[ENTER]

Select Test Mode

[ENTER]

Select Device (Human Circuit Model)

[ENTER]

Select Line (Fault Simulation)

[ENTER]

Select High Limit

[ENTER]

Select Low Limit

[ENTER]

Select Power (DUT Power Monitor)

[ENTER]

Select High Limit

[ENTER]

Select Low Limit

[ENTER]

Select Test Time

[ENTER] [PROG]

Display Reads:

Select Step = 1
1 - 10 (UP/DOWN)

Press UP or DOWN arrow key to enter test step

Select Mode = LC
Press (UP/DOWN)

Device = D1 UL544NP
Select by UP/DOWN

Line = LO NORMAL
Select by UP/DOWN

Press UP arrow key to display line (Normal, Reverse, Single Fault Normal, Single Fault Reverse)

High Limit = 6.000 mA
0.001 - 9.999 mA

Press Numerical & Decimal keys to enter high current limit

Low Limit = Disable
0 - 9.999 mA 0 = Disable

Press Numerical & Decimal keys to enter low current limit

POWER = VOLTAGE
Select by Up/DOWN

Press UP arrow key to display power mode (V, A or VA)

VA High = Disable
0 - 2200 VA 0=Disable

Press Numerical & Decimal keys to enter high power limit

VA Low = Disable
0 - 2200 VA 0 = Disable

Press Numerical & Decimal keys to enter low power limit

Test Time = 3.0 s
0 - 999 s 0 = Disable

Press Numerical & Decimal keys to enter test time

STEP - 01 D1 L0 3.0 s
Disable LC 6.000 mA

2.7 Pause Mode

“PAUSE” is a mode selection that allows a test sequence to be stopped while test leads are changed or other operations performed. A 20-character user programmable message will be displayed on the screen when in PAUSE mode and the test will continue when the [TEST] button is pressed or start initiated via remote I/O. The Under Test relay on the remote I/O can also be cycled during PAUSE if required.

Instrument Operation in PAUSE Mode:

Up/Down (↑ ↓) arrow can be used to cycle through alphanumeric characters.

Right/Left (⇒ ⇐) arrows go to next or previous character.

Under Test “ON/OFF”:

When ON, the under test relay on remote I/O is closed during Pause mode.

When OFF, the under test relay is open on remote I/O during Pause mode.

During test sequence when a Pause is encountered the tester stops, displays Pause and 20 character message until test button is pressed again or start is initiated via remote I/O.

PAUSE programming menu:

Press [BUTTON]:

[PROG]

Select Test Step

[ENTER]

Select Test Mode

[ENTER]

Select message displayed in Pause Mode

[ENTER]

Select status of Under Test Relay

[ENTER]

[PROG]

Display Reads:

Select Step = 1
1 - 99 (UP/DOWN)

Press UP or DOWN arrow key to enter test step

Select Mode = PAUSE
Press (UP/DOWN)

Pause String =
1

Press Numerical & Decimal keys to enter message

Under Test = OFF
Select by UP/DOWN

Press UP or DOWN arrow key to select ON or OFF

Exit Programming Mode & return to test mode

2.8 Programming A Multi-Step Test

Each test can consist of 1 to 99 steps in sequence, for example, a typical three step test might be a Ground Bond test followed by an AC hipot test and then an IR test. Each step may be programmed for any available function (WAC, WDC, IR, GR or LC) with programmed test conditions independent from the other step.

To change the test mode proceed as follows:

- Press **[STOP]**

Step-01	1.0s
1.200KV WAC	7.50mA

- Press **[UP]arrow**
To select/examine steps 2-99

Step-02	1.0s
1.500KV WDC	15.00mA

Step-03	1.0s
0.750KV IR	1.0MΩ

Step-04	1.0s
20.00A GR	100.0mΩ

- Press **[DOWN] arrow**
To return to lower steps.

Step-01	1.0s
1.200KV WAC	7.50mA

- **NOTE for a SINGLE STEP TEST**

The test voltage (or current for a ground continuity test) for Step 2 must be set to 0.00. Likewise, for a TWO STEP test the voltage or current for Step 3 must be set to 0.00.

- To change a test mode select the step to be changed (1 to 99) as described above.

- Press **[PROG]**

Select Step = 1
1-99 (UP/DOWN)

- Press **[UP] arrow key**
To select step to be changed

Step-01	1.0s
1.200KV WAC	15.00mA

- Press **[ENTER]**

Select Mode = WAC
Press UP/DOWN

- REPROGRAM per paragraphs 2.3.1 (AC Hipot), 2.3.2 (DC Hipot), 2.4 (IR) 2.5 (Ground Bond) and 2.6 (Leakage Current).

2.9 Storing a Test Setup

2.9.1 Storing a Single Step Test

To store a test setup, program the test in accordance with your test specification and paragraphs 2.3.1, 2.3.2, 2.4, 2.5 or 2.6 of this manual. Follow the procedure illustrated below.

Press [Sto]

Store Memory : _1 1

Enter storage location for test setup

Store Memory : 12 -

Press [ENTER]

Enter additional alpha numeric name* for memory location (If desired). Otherwise press ENTER.

Store Memory : 12 Store ?

Press [ENTER]

Step-01 1.0s 1.200KV WAC 7.50mA
--

*** To create an alpha numeric name for a particular memory location:**

- Use the [↑] arrow or [↓] arrow to scroll through numeric characters 0-9 then alpha characters A-Z.
- To select the number or letter you want, press the right arrow [⇒].
- Then choose next number or letter and press the right arrow [⇒] again.
- Up to 11 digits can be used to identify the location name.
- When you are finished naming the location, press [ENTER] to accept.

2.9.2 Storing a Multi-Step Test

To store a multi-step test, program the tests in accordance with your test specification and paragraphs 2.3.1, 2.3.2, 2.4, 2.5, 2.6 and 2.7 of this manual. An example of an AC/IR/GR test sequence is illustrated below.

Press **[PROG]**

Select Step 01

Press **[ENTER]** GR Test per ¶ 2.5

*

*

*

continue entering GR test setup

After entering TEST Time, Display reads Select Step = 2

Select Step 02

Press **[ENTER]** AC Test per ¶ 2.3.1

*

*

*

continue entering AC test setup

After entering RAMP Time, display reads Select Step = 3

Select Step 03

Press **[ENTER]** IR Test per ¶ 2.4

*

*

*

continue entering IR test setup

After entering RAMP Time, Press **[PROG]**

Press **[Sto]**

Store Memory : _1 1

Enter storage location

Store Memory : _ 3

Press **[ENTER]**

Enter additional alpha numeric name* for memory location (If desired). Otherwise press ENTER.

Store Memory : 3 -

Press **[ENTER]**

Store Memory : 3 Store ?

Press **[ENTER]**

M03 S - 01 10.0s 1.00A GR 100.0mΩ

To verify the storage, press **[Rcl]** once. Enter the storage location. Press **[ENTER]** three times. Use **[UP]** arrow key to view Steps 02 and 03. Use **DOWN** arrow key to return to Step 01.

2.10 Instrument Zeroing/Offset

The Guardian 6200 instrument provides automatic zeroing/offset for lead or fixture effects. During the zeroing/offset process a correction is made (subtracted out) as the result of lead leakage current and stored in instrument memory to be applied to ongoing measurements. For maximum measurement accuracy it is recommended that the unit be zeroed after power-up, any time the test parameters are changed and any time the test leads or fixture are changed. The offset can be saved under setup storage, 1 - 99 setups, and is saved on a power down and power back up. The program must be stored after the offset is obtained. Refer to ¶ 2.9 for instructions on storing a test setup. **The instrument should warm-up for at least 15 minutes before zeroing. REFER TO ¶ 2.10 FOR THE CORRECT CABLE CONNECTION.**

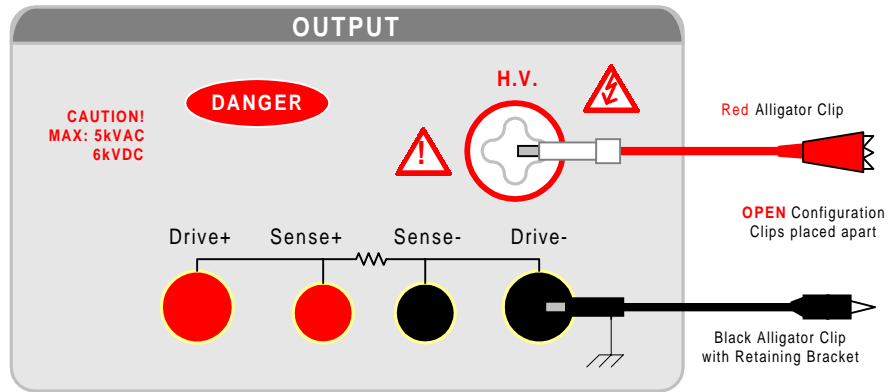

Figure 2-5: Zero/Offset OPEN Configuration

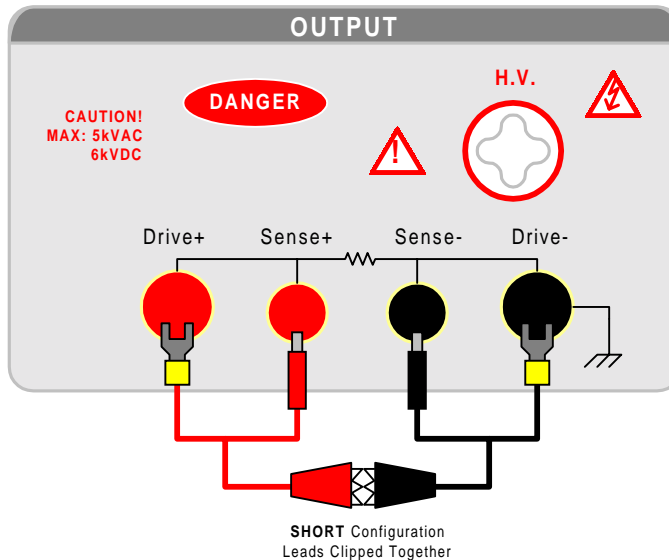

Figure 2-6: Zero/Offset SHORT Configuration

Proceed as follows for automatic zeroing/offset:

- Plug the appropriate cable (or other fixture) into the OUTPUT connectors, **with no device connected**. Refer to paragraph 2.10 for cable configurations based on test to be made. **NOTE:** Test leads for AC Hipot, DC Hipot and IR measurements should be OPEN, for GR should be SHORTED. The G30 corded product adapter for LC (or any test) should have **no** DUT connected when performing the OFFSET function.
- Press the [OFFSET] key.

Offset is GET Press Test Key.

- Press the green [TEST] button.
Green Offset LED is lit

Step-01 Pass 0.0s 1.200KV WAC 0.038mA
--
- Press the [OFFSET] key.
Green Offset LED is lit

Offset is ON Press the Offset Key.

- Press the [OFFSET] key once.

Offset is OFF Press the Offset Key.
--
- Press the [ENTER] key to accept
OFFSET ON or OFF

Step-01 1.0s 1.200KV WAC 7.50mA

The following formulas apply to the offset function:

For AC offset current < 100μA:

$$\text{Display current} = \sqrt{(\text{current read})^2 - (\text{offset current})^2}$$

For DC offset or AC offset current ≥ 100μA:

$$\text{Display current} = (\text{current read}) - (\text{offset current})$$

For LC Offset current (for all values):

$$\text{Display current} = I_{\text{DISPLAYED}} = (I_{\text{MEAS}} - I_{\text{OFFSET}})$$

2.11 Connection to Device Under Test

Before connecting the device for test press the red **[STOP]** key and make sure the red **DANGER** light is **OFF**.

Depending on the test to be conducted (Hipot, IR or Ground Bond) connect the test cables to the OUTPUT connectors. Refer to the following figures to determine the correct configuration. When using the black cable, with the metal retaining bracket, make sure it is locked behind the connector to prevent this cable from accidentally coming loose.

WARNING

NEVER TOUCH THE TEST LEADS OR THE DEVICE UNDER TEST WHEN THEY ARE CONNECTED TO THE INSTRUMENT AND THE RED **DANGER LIGHT IS ON OR FLASHING.**

NOTE:

The connections to the front panel output terminals permit AC Hipot, DC Hipot, IR, and Ground Bond tests to be performed on the device under test (DUT).

For true Earth Leakage, use the rear panel connections as illustrated in paragraph 2.6.2.1. Hipot, IR and Ground Bond tests can also be done from the rear output terminals

Connection to DUT using the S02 Cable Lead Set

To perform a AC/DC Hipot or Insulation Resistance test from the front panel of the Guardian 6200, the S02 leads are connected as illustrated in Figure 2-7. The white custom banana plug lead is connected between the HV output terminal and the high side of the DUT. The black banana plug is connected between the DRIVE- terminal and the low side of the DUT.

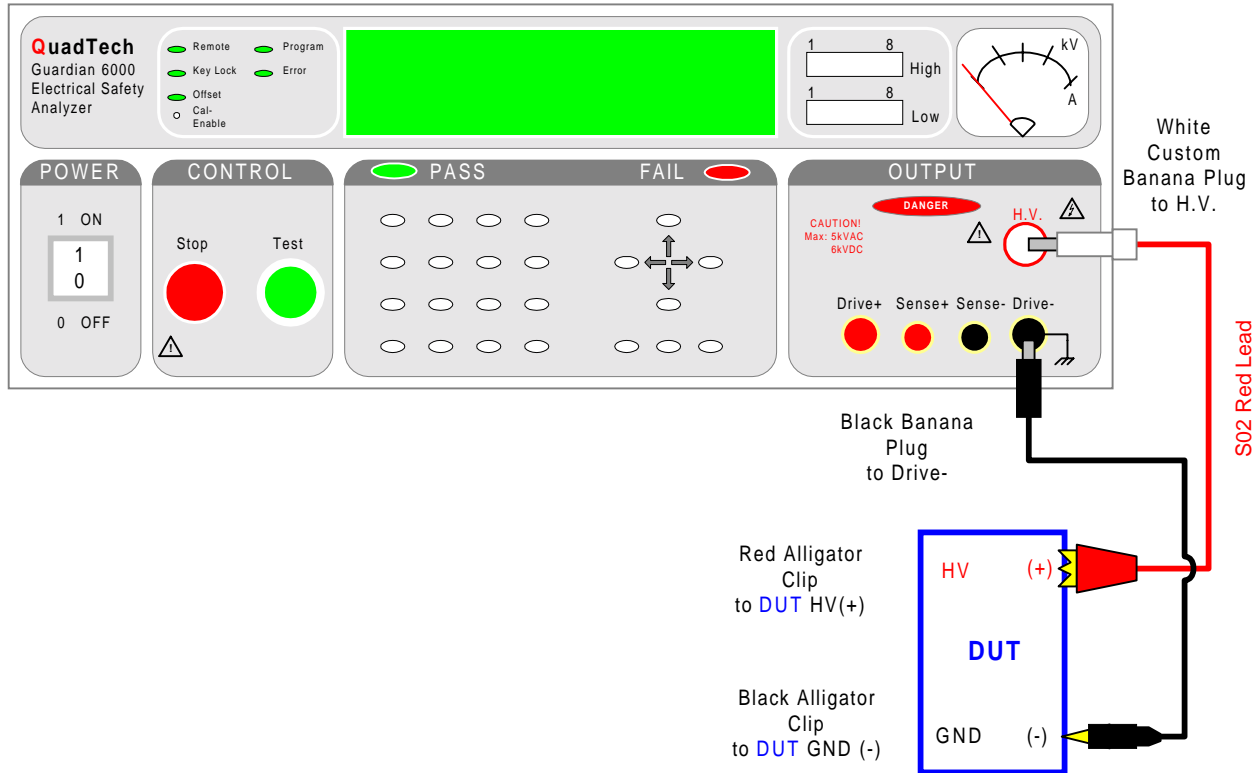

Figure 2-7: Connection for Hipot/IR Test (Using S02 Cable Lead Set)

Connection to DUT using G15 Cable Lead Set

To perform a Ground Bond test from the front panel of the Guardian 6200, the G15 leads are connected as illustrated in Figure 2-8. The black banana plug and spade lug are connected to the SENSE- and DRIVE- terminals and the black alligator clip is connected to the low side (GND) of the DUT. The red banana plug and spade lug are connected to the SENSE+ and DRIVE+ terminals and the red alligator clip is connected to the case of the DUT.

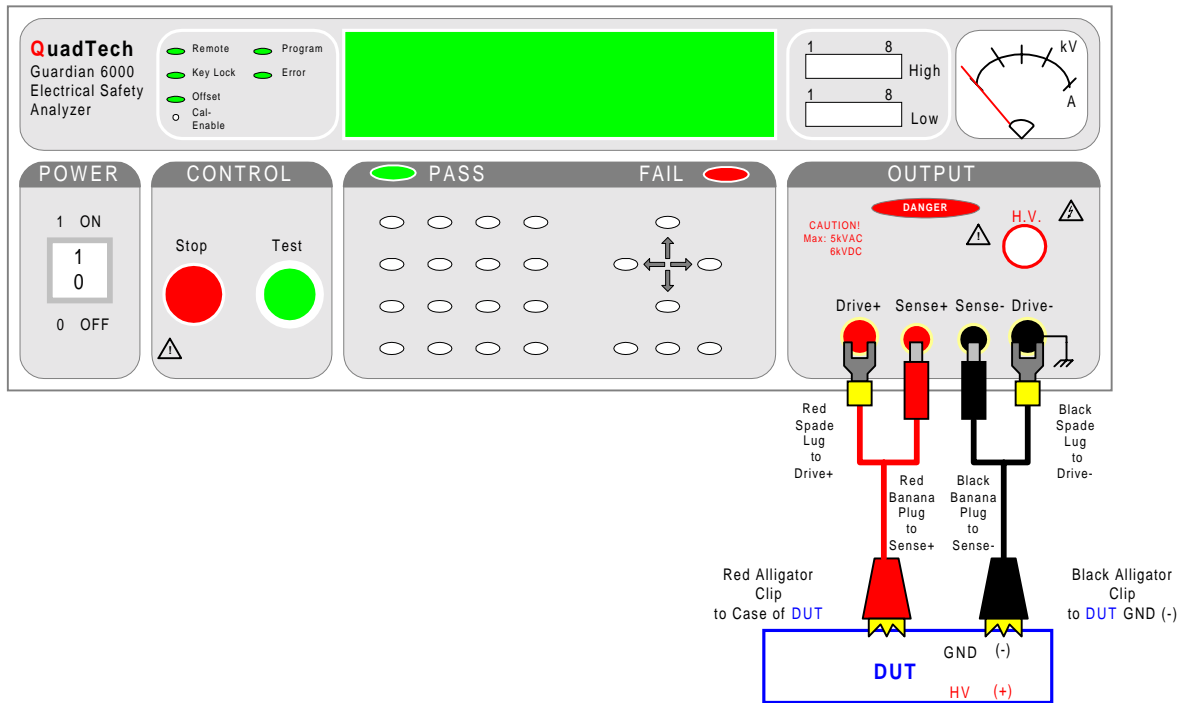

Figure 2-8: Connection for Ground Bond Test (Using G15 Cable Lead Set)

Connection to DUT using S02 and G15 Cable Lead Sets

To perform a AC/DC Hipot, Insulation Resistance or Ground Bond test from the front panel of the Guardian 6200, the S02 and G15 leads are connected as illustrated in Figure 2-9. The white custom banana plug lead is connected between the HV output terminal and the high side of the DUT. The black banana plug and spade lug are connected to the SENSE- and DRIVE- terminals and the black alligator clip is connected to the low side (GND) of the DUT. The red banana plug and spade lug are connected to the SENSE+ and DRIVE+ terminals and the red alligator clip is connected to the case of the DUT.

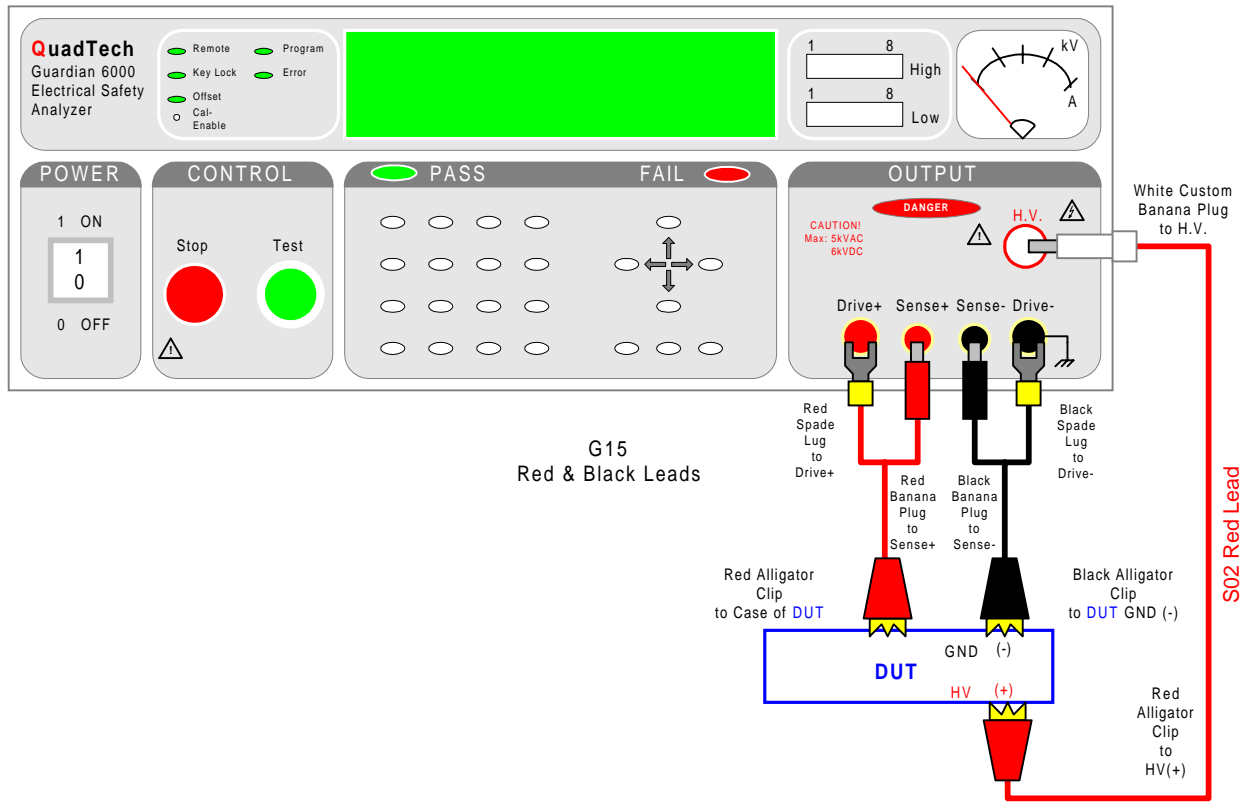

Figure 2-9: Connection for Hipot & GR Test (Using S02 & G15 Lead Sets)

Connection to DUT using G33 Power Entry Adapter

To perform a leakage current test and hipot test, the G33 power entry adapter is connected to the rear panel of the Guardian 6200 as illustrated in Figure 2-10. The black banana plug and spade are connected to the SENSE- and DRIVE- output terminals. The two white custom banana plugs are connected to the L-OUT and N-OUT terminals on the 6000-04 scanner. The G33 power entry adapter is then plugged into the DUT's AC outlet module. The red G15 lead can be attached to the Drive- and Sense- terminals if a Ground Bond test is also desired.

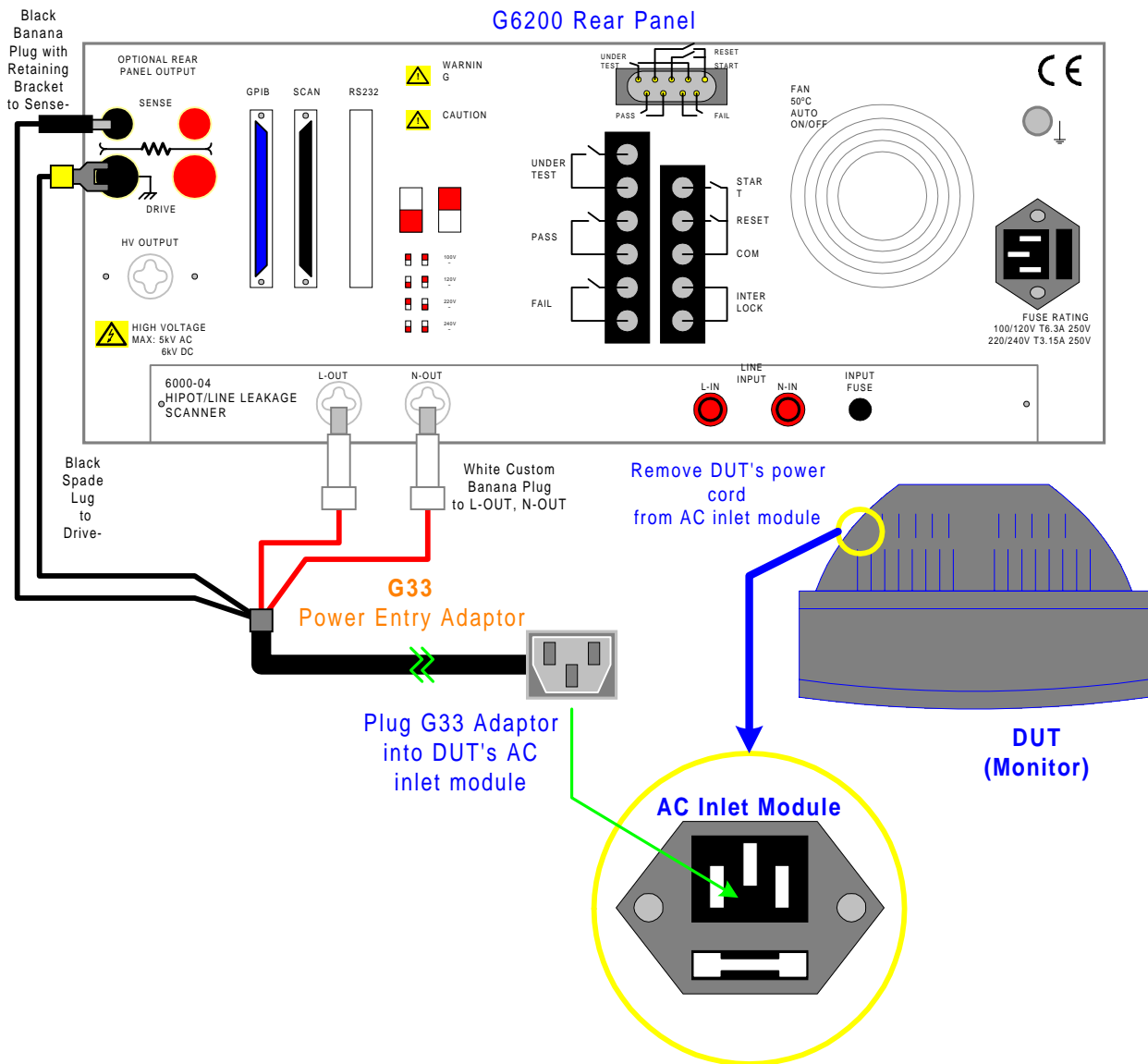

Figure 2-10: Connection for Leakage Current & Hipot Tests (Using G33 Adapter)

2.12 Measurement Procedure

Before a measurement is made, verify the following:

- 1 Guardian 6200 unit power is ON
- 2 15 minute warm-up
- 3 Test parameters programmed
- 4 Test Setup stored
- 5 Offset function selected
- 6 Device Under Test (DUT) connected

The operator has a choice of performing a test at power-up conditions (test conditions at which the instrument was last powered down), or recalling one of 99 possible stored setups. Refer to paragraphs 2.3, 2.4, 2.5, 2.6, 2.7 or 2.8 for instructions to change the test mode and/or test conditions.

To initiate a test at “power-up conditions” proceed as follows:

- Press **[STOP]**
Green Offset LED is lit

Step-01	1.0s
1.200KV WAC	7.50mA

- Press **[TEST]**
Danger LED flashes, Offset LED is lit
Green PASS LED is lit

Step- 01 Pass	0.0s
1.200KV WAC	0.012mA

- Press **[STOP]**
Any time to stop test
Green Offset LED is lit

Step-01	1.0s
1.200KV WAC	7.50mA

To RECALL one of the 99 setups proceed as follows:

- Press the **[RCL]** key.

Recall Memory : _1
1

- Enter storage number of test setup
Press **[ENTER]**

Recall Memory : _2

- Press **[ENTER]**

Recall Memory : 2
Recall?

- Press **[ENTER]**

M02 S01	1.0s
1.200KV WAC	7.50mA

2.13 Initial Parameter Settings

The Guardian 6200 unit has a number of parameter settings that seldom require change, the instrument will power-up with default settings. Each of these parameters are listed in the Table 2-4 and can be changed using the following procedure.

Table 2-4: Initial Parameter Setting

Display	Range	Default Value
A General Setting		
Contrast	1-15	6
Beep Vol.	ON : 1,2,3 / OFF	3
Scan No.	1-8	1
Fail Retest	ON/OFF	OFF
Print PASS	ON/OFF	OFF
Print FAIL	ON/OFF	OFF
Timer U/D	UP/DOWN	DOWN
B Timing Setting		
Pass Hold	0.2-99.9s	0.5
Step Hold	ON : 0, 0.1-99.9s	0.2
Judg. Wait	0.1-1.0s	0.3
DC Wait	0.0-99.9s	0.0
C Special Setting		
AC-V Freq.	50-600 Hz	60
G-R Freq.	50-60 Hz	60
G-R Voltage	6.0-15.0 V	15.0
WV A Range	ON/OFF	OFF
IR A Range	ON/OFF	ON
Soft. AGC	ON/OFF	ON
Password	ON/OFF	OFF
G-R Cont.	ON/OFF	OFF
IEC601-1	ON/OFF	OFF
Lock Rcl	ON/OFF	OFF
Discharge	0.05 5.1kV	5.1kV
D Remote Setting		
GPIB Addr.	1-31	3
Baud Rate	0.3, 1.2, 2.4, 4.8, 9.6, 19.2 kbps	9.6
GPIB Comp.	ON/OFF	OFF

To select initial parameter setting mode:

Press [ENTER] and then [6] [2] [0] [0].

A. General Setting

Press → (Press numerical keys & ENTER)

1. Contrast = _ 4
1-15

Press ↑ (Press OFF Key & ENTER)

2. Beep Vol. = OFF
Off /1/2/3 (OFF Key)

Press ↑ (Press numerical keys & ENTER)

3. Scan NO. = _ 1
1-8

Press ↑ (Press OFF Key & ENTER)

4. Fail Retest = OFF
On/Off (OFF Key)

Press ↑ (Press OFF Key & ENTER)

5. Print PASS = OFF
On/Off (OFF Key)

Press ↑ (Press OFF Key & ENTER)

6. Print FAIL = OFF
On/Off (OFF Key)

Press ↑ (Press OFF Key & ENTER)

7. Timer U/D = Down
Up/Down (OFF Key)

Press ←

A. General Setting

Press ↑

B. Timing Setting

Press → (Press numerical keys & ENTER)

1. Pass Hold = _ 1.0s
0.2 – 99.9s

Press ↑ (Press numerical keys & ENTER)

2. Step Hold = _ 1.0s
On, 0.1 – 99.9s

Press ↑ (Press numerical keys & ENTER)

3. Judg. Wait = _ 0.1s
0.1 – 99.9s

Press ↑ (Press numerical keys & ENTER)

4. DC Wait = _ 0.0s
0.0 – 99.9s

Press ←	B. Timing Setting
Press ↑	C. Special Setting
Press → (Press numerical keys & ENTER)	1. AC-V Freq. = _ 60Hz 50 - 600 Hz
Press ↑ (Press numerical keys & ENTER)	2. G-R Freq. = _ 60Hz 50 - 60 Hz
Press ↑ (Press numerical keys & ENTER)	3. G-R Volt. = <u>1</u> 5.0V 6.0 - 15.0 V
Press ↑ (Press OFF Key & ENTER)	4. WV A Range = OFF On/Off (OFF Key)
Press ↑ (Press OFF Key & ENTER)	5. IR A Range = ON On/Off (OFF Key)
Press ↑ (Press OFF Key & ENTER)	6. Soft. AGC = ON On/Off (OFF Key)
Press ↑ (Press OFF Key & ENTER)	7. Password = OFF On/Off (OFF Key)
Press ↑ (Press OFF Key & ENTER)	8. G-R Cont. = OFF On/Off (OFF Key)
Press ↑ (Press OFF Key & ENTER)	9. IEC601-1 = OFF On/Off (OFF Key)
Press ↑ (Press OFF Key & ENTER)	10. Lock Rcl = OFF On/Off (OFF Key)
Press ↑ (Press OFF Key & ENTER)	11. Discharge = 5.10kV 0.50 - 5.1 kV

Press ←	C. Special Setting
Press ↑	D. Remote Setting
Press → (Press numerical keys & ENTER)	1. GPIB Addr. = _ 3 1 - 31
Press ↑ (Press numerical keys & ENTER)	2. Baud Rate = 9600 0.3 – 19.2 (OFF Key)
Press ↑ (Press OFF Key & ENTER)	3. GPIB Comp. = OFF On/Off (OFF Key)

Shown above is the entire scroll through the initial parameter settings. The parameters can be changed singularly. To exit Initial Parameter Setting mode, press [PROG]. The display will return to test set-up.

2.13.1 General Settings

In Initial Parameter Setting mode, the Guardian 6200 unit has six programmable parameters listed under “General Setting”. These parameters are Contrast, Beep Volume, Scan Number, Fail Retest, Print PASS, Print FAIL and Timer U/D.

2.13.1.1 Contrast

The Contrast of the display is adjustable from 1 – 15. A value of 1 is brightest, a value of 15 is darkest. The default setting for Contrast is 6.

NOTE

Contrast can be adjusted at any time the unit is powered up by pressing the left/right arrow key.
If display is totally blank, press the right arrow key to bring the Contrast back.

2.13.1.2 Beep Volume

The volume of the buzzer has four levels of adjustment : OFF, 1, 2 & 3. When OFF is selected the buzzer will not sound. When [1] is selected the buzzer emits a low volume sound. [2] corresponds to a mid level volume and [3] corresponds to a high level volume. The instrument default value is 3 for Beep Volume.

2.13.1.3 Scan Number

The Scan No. setting permits the user to specify the number of scanners connected to the Guardian 6200 instrument. The range is 1 – 8 and the default value is 1 (Internal Scanner: 6000-04).

2.13.1.4 Fail Retest

The Fail Retest setting allows the option of automatic retest of a device upon fail. The programmable setting is ON or OFF and the default setting is OFF.

2.13.1.5 Print PASS

The Print PASS function of the G6200 unit is used in conjunction with the printer interface. The instrument default value is OFF. When Print PASS is selected ON, the test data will be printed out when a PASS occurs.

2.13.1.6 Print FAIL

The Print FAIL function of the G6200 unit is used in conjunction with the printer interface. The instrument default value is OFF. When Print FAIL is selected ON, the test data will be printed out when a FAIL occurs.

2.13.1.7 Timer U/D

Timer U/D controls/changes whether the test time counts down or counts up. The range for Timer U/D is UP or DOWN and the default value is DOWN.

2.13.2 Timing Settings

In Initial Parameter Setting mode, the Guardian 6200 has four programmable parameters listed under “Timing Setting”. These parameters are Pass Hold, Step Hold, and Judgement Wait and DC Wait.

2.13.2.1 Pass Hold

The Pass Hold setting allows the option of programming a hold time for the PASS relay (at Remote Interface) after a single or multiple step test. The range for Pass Hold is 0.2 – 99.9 sec and the instrument default value is 0.5sec. Refer to Figure 2-11.

2.13.2.2 Step Hold

The Step Hold setting allows the option of programming a hold time between steps. The range for Step Hold is ON or 0.1 – 99.9seconds. The instrument default value is 0.2sec. When Step Hold is ON, the test will stop after one step and display PASS/FAIL. Refer to Figure 2-11.

2.13.2.3 Judgement Wait

The Judg. Wait setting allows the option of programming a hold time on each test. This allows the device to be fully charged prior to a measurement being made and then judged PASS/FAIL. The range for Judg. Wait is 0.1 – 99.9sec and the instrument default value is 0.3sec. Refer to Figure 2-11.

2.13.2.4 DC Wait

DC Wait is for a discharge time (discharge circuit is in effect) after the measurement for DC HIPOT ONLY. The range for DC Wait is adjustable from 0.0 to 99.9 seconds and the default value is 0.0s.

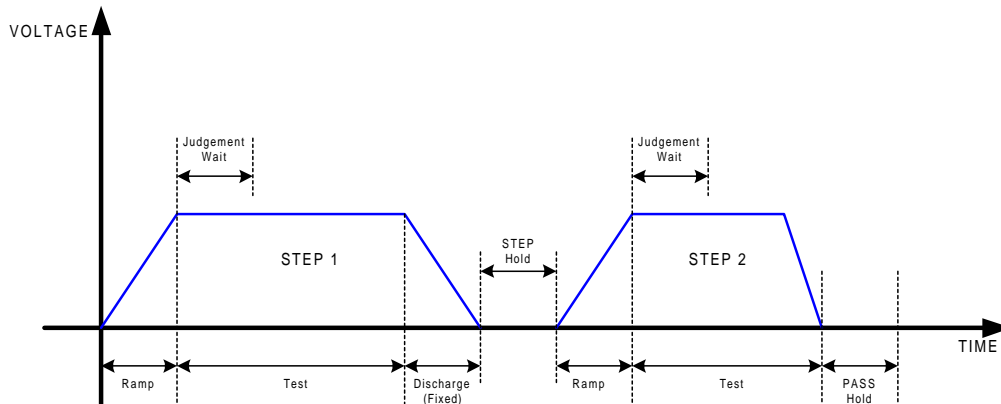

Figure 2-11: Timing Diagram G6200 Hold Settings

2.13.3 Special Settings

In Initial Parameter Setting mode, the Guardian 6200 has eleven programmable parameters listed under “Special Setting”. These parameters are AC-V Frequency, G-R Frequency, G-R Voltage, WV A Range, IR A Range, Software AGC, Password, GR Continue-on-Fail, IEC601-1, Lock Recall and Discharge.

2.13.3.1 AC-V Freq.

The AC V Freq. setting allows the option of programming the frequency for the AC hipot test. The range of AC-V Freq. is 50 – 600Hz and the instrument default value is 60Hz.

2.13.3.2 G-R Freq.

The G-R Freq. setting allows the option of programming the frequency for the Ground Continuity (GR) test. The range of G-R Freq. is 50 – 60 Hz and the default value is 60Hz.

2.13.3.3 G-R Volt

The G-R Volt setting allows the option of programming the maximum open circuit output voltage for the Ground Continuity (GR) test. The range of G-R Volt is 6.0 – 15.0V and the default value is 15.0V.

2.13.3.4 WV A Range

The Withstanding Voltage Auto Range setting permits the use the full scale current range (ON) or using the user programmed maximum current limit (OFF). The low current range (3mA full scale) results in increased measurement resolution. The default value of WV Auto Range is OFF.

2.13.3.5 IR A Range

The Insulation Resistance Auto Range function sets auto range off or on for insulation resistance measurements. When IR A Range is ON, the G6200 selects the resistance range depending on the programmed test voltage. The default value of IR Auto Range is ON. When IR A Range is selected OFF, the IR measurement speed increases by 50% but the accuracy will decrease.

2.13.3.6 Software AGC

The Software Automatic Gain Control (AGC) setting allows the option of correcting the output voltage (ON). This is okay when measuring resistors but under special circumstances when measuring large capacitive devices it is best to select Soft. AGC OFF. The default value is ON.

2.13.3.7 Password

The Password setting allows the option of locking out the System Settings, Clear RAM and Key Lock functions when ON is selected. The password can be up to 8 digits using the numerical keys 0 through 9. When a password is entered, the G6200 comes back with “CHK : _” and the password needs to be entered a second time to identify. Pressing the [Dele] key will clear the password just entered. This password will also change the password for front panel lockout. If the password function has been turned ON and a password entered, then System Settings, Clear RAM and Key Lock are de-activated. The override to a password is [ENTER] [8][5][2][4][6][3][1][7][9] [ENTER]. The display will then show the password. Return to System (Special) Settings to disable the password function. Figure 2-12 illustrates the password setting function.

Press [BUTTON]:

[ENTER] [6] [2] [0] [0]

↓ ↓

→

↓ ↓ ... ↓

[Off]

[1] [2] [3]

(Example Password)

[ENTER]

[1] [2] [3] [ENTER]

[PROG]

Display Reads:

A. General Setting

C. Special Setting

1. AC-V Freq = _ 60Hz
50 - 600Hz

6. Password = OFF
On/Off (OFF Key)

S/N: __

S/N: * * * _

S/N: * * * _
CHK: _

6. Password = ON
On/Off (OFF Key)

Step-01 0.0s
1.000kV WAC 1.0M Ω

Turn instrument OFF. Turn instrument ON again.

[ENTER] [6] [2] [0] [0] DOES **NOT** BRING UP SYSTEM SETTINGS!

Use PASSWORD OVERRIDE to display current password.

[ENTER] [8] [5] [2] [4] [6] [3] [1] [7] [9] [ENTER]

S/N: 123

[ENTER] [1] [2] [3] **(Enables System Settings)**

A. General Setting

[CLEAR] [1] [2] [3] [CLEAR] **(Enables Clear RAM)**

Clear Memory?
ENTER = Yes

[1] [2] [3] [Off]

(Enables Key Lock)

Step-01 0.0s
1.000kV WAC 1.0M Ω

Figure 2-12: Setting a Password

2.13.3.8 G-R Cont.

The Ground Resistance Continue-on-Fail function of the Guardian 6200 can be selected ON or OFF. The instrument default value is OFF. When G-R Cont. is selected ON, the unit will continuously operate in GR mode and will not stop the measurement if a failure occurs. The Pass/Fail and output relay operate normally. The buzzer will continuously sound if a failure occurred during the test. This function allows manual probing of continuity on a product.

2.13.3.9 IEC601-1

The IEC601-1 feature is applicable to (WDC) DC hipot only. This test is basically Insulation Breakdown per IEC601-1, Clause 20. The G6200 unit will initially apply $\frac{1}{2}$ the programmed test voltage, then gradually apply a linear ramp to the test voltage over the programmed ramp time until the required test voltage is achieved. The G6200 holds the voltage for the programmed test time then ramps back down identical to the ramp up.

2.13.3.10 Lock Rcl

“Lock Rcl” is used to lockout the ability to recall stored information. The range for Lock Rcl is ON or OFF and the default value is OFF. When the front panel is locked using the “Key Lock” function (§2.13) memory locations may or may not be recalled. If Lock Rcl is ON, memory locations can **not** be recalled when “Key Lock” is ON. When Lock Rcl is OFF, memory locations can be recalled.

2.13.3.11 Discharge

The Discharge function permits the user to set the value of the voltage that the G6200 instrument will discharge to upon completion of a hipot test. The range is 0.05kV to 5.10kV and the instrument default value is 5.10kV. The time it will take to discharge to a specific voltage is dependent on the capacitance of the DUT. The Discharge time is a natural log function.

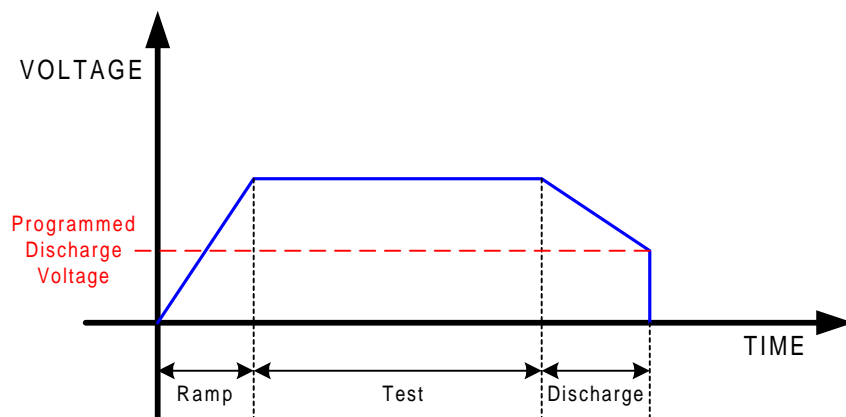

Figure 2-13: Discharge

2.13.4 Remote Settings

In Initial Parameter Setting Mode, the Guardian 6200 has three programmable parameters listed under “Remote Setting”. These parameters are GPIB Address, Baud Rate and GPIB Compatibility.

2.13.4.1 GPIB Address

The GPIB Addr. setting allows the user to program a GPIB (IEEE-488) address. The range is 1 – 31 and the instrument default value is 3.

2.13.4.2 Baud Rate

The Baud Rate setting allows the option of selecting the Baud Rate in kbps. The range is 0.3, 1.2, 2.4, 4.8, 9.6, and 19.2 kbps. The instrument default value is 9.6 kbps.

2.13.4.3 GPIB Compatibility

“GPIB Comp” is the compatibility function of the G6200 unit. “GPIB Comp” can be selected ON or OFF. The instrument default value is OFF. When selected ON, the Guardian 6200 GPIB data output is compatible with the Guardian 5000 GPIB data output.

2.14 Front Panel Lockout

With front panel lock in effect the ability to change test conditions is prohibited. Only the **[TEST]** and **[STOP]** buttons and the setup recall function (RCL) are functional.

To activate the front panel lockout:

- With the instrument in standby status (Stop button previously pressed and no lights blinking) enter **[6] [2] [0] [0]** and **[OFF]** from the data entry keys. The green KEY LOCK indicator light will illuminate indicating the instrument is in the lockout state. The display shows the test set-up.

To deactivate the front panel lockout:

- With the instrument in standby status (Stop button previously pressed and no lights blinking) enter **[6] [2] [0] [0]** and **[OFF]** from the data entry keys. The green KEY LOCK indicator light will go out indicating the instrument is no longer in the lockout state. The display shows the test set-up.

NOTE

Code for lockout will change if password has been entered (¶ 2.12.3.7)

2.15 Clear Setup Memory

All stored test conditions in instrument memory (99 setups) can be cleared with a few key strokes.

To clear setup memory:

- With the instrument in standby status (Stop button previously pressed and no lights flashing) press [CLEAR] and then [6] [2] [0] [0] and [CLEAR] again.

Clear Memory ?
ENTER = Yes

- Press [ENTER]

Guardian 6200
AC LF IS 60Hz

GPIB Address : 03
Baud Rate : 9600

- The Beeper sounds loud (to alert that memory has been cleared) and all LED's flash once. The display is held for just a few seconds and then reverts to the test set-up display.
- The Beeper will remain ON until it is turned OFF by entering Initial Parameter Setting mode [ENTER 6200], selecting [A. General Setting], [2. Beep Vol. = OFF] and pressing [ENTER]. Remember to press [PROG] to exit Initial Parameter Setting and return to test set-up display.

2.16 Software Version Display

The version of software installed in the instrument can be displayed on the front panel.

To display software version:

- Press [POWER] switch to ON (1) and immediately after the Pass & Fail LEDs turn off, Press the [ENTER] key.

Guardian 6200
Version 1.00

GPIB Address : 03
Baud Rate : 9600

- The Display is held for just a few seconds and then reverts to the test set-up display.

Section 3 : Interface

3.1 Remote

A 9 pin D-series remote control connector is located on the rear panel of the G6200 instrument. There is a black 6 screw relay strip for the remote output signals : UNDER TEST, PASS & FAIL. There is a black 5 screw relay strip for the remote input connections : START, RESET, COM & INTER LOCK.

Inputs require a contact closure and outputs provide a contact closure, as shown in the figure below.

Before connecting the instrument to its power source the **interlock function** on the rear panel remote connector must be properly utilized. **This is an important safety feature for the protection of the operator.** Turn on of the instrument's high voltage is inhibited with no interlock connection and is functional with the interlock jumper in place (as shipped from the factory).

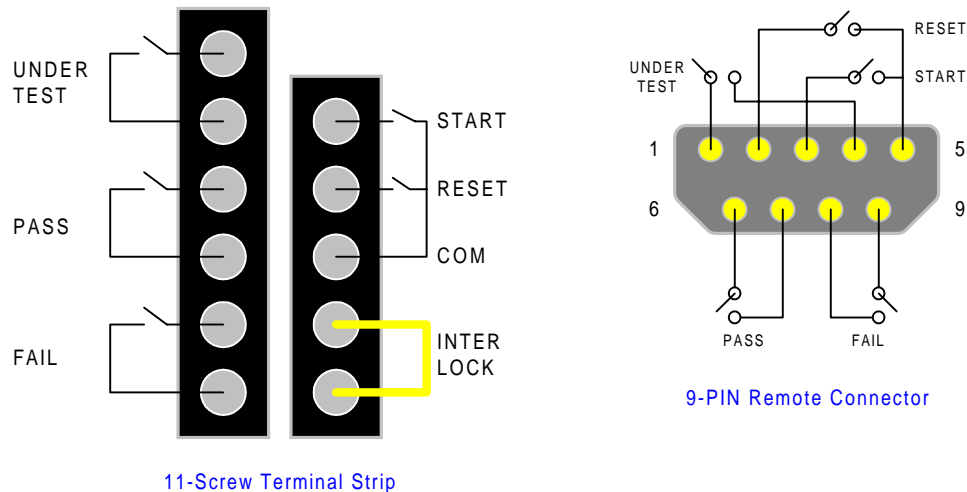

Figure 3-1: Remote Control Connector

The G6200 instrument has three output signals on the rear panel. The UNDER TEST output terminal is short during TEST as the relay contacts connect to the device powered by 115VAC and current < 0.3A. The PASS output terminal is short when the DUT is judged GOOD. The FAIL output terminal is short when the DUT is judged NO GOOD.

Figures 3-2 and 3-3 illustrate possible remote control connections. Use extreme care when using a remote control connection as the High Voltage Output is being turned ON and OFF with with an external signal.

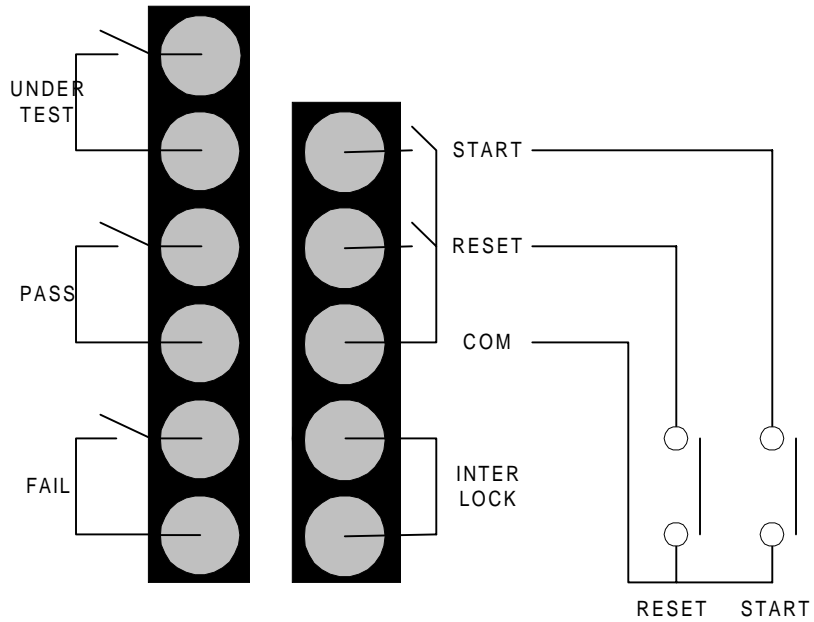

Figure 3-2: Single Control of TEST or STOP

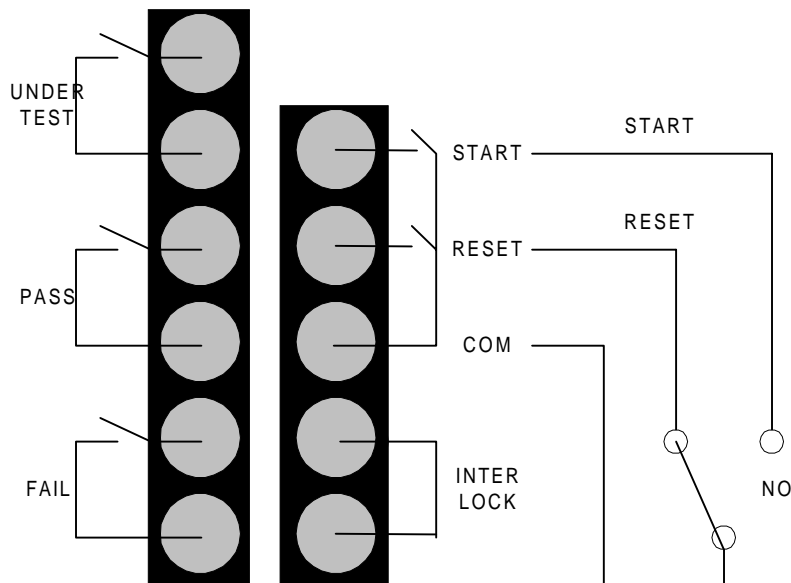

Figure 3-3: Continuous Control of STOP

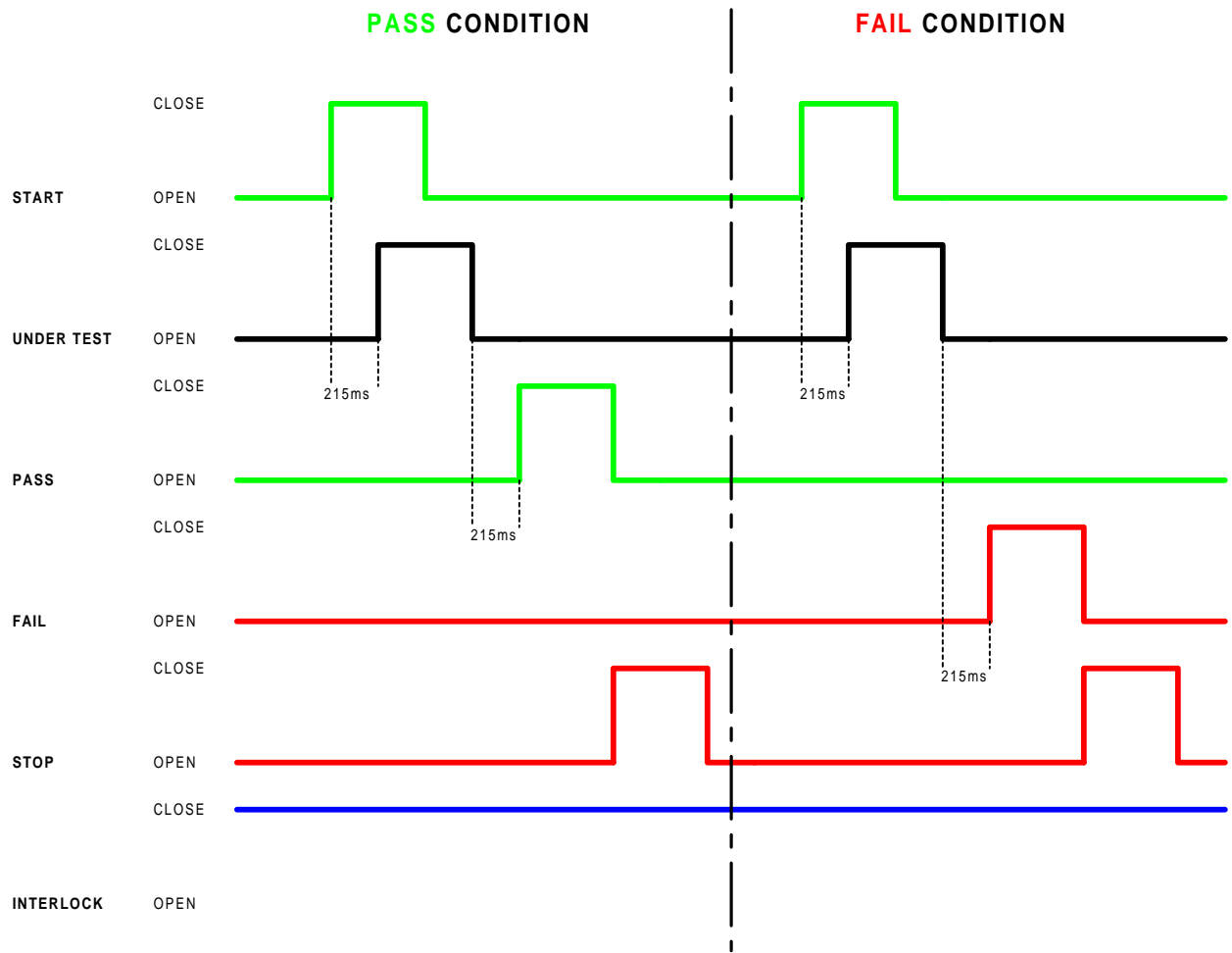

Figure 3-4: G6200 Timing Diagram

3.2 RS232 Interface

3.2.1 PIN Configuration

An optional RS232 interface is available for the Guardian 6200 instrument. The interface is factory installed when the instrument is ordered. Connection is through the black 25-PIN connector labeled 'RS232' on the rear panel of the Guardian 6200 unit. Figure 3-5 illustrates the RS232 PIN configuration.

NOTE

When the RS232 Interface and the IEEE-488 Interface are both installed in a Guardian 6200 unit, only one of the two interfaces may be activated at a time.

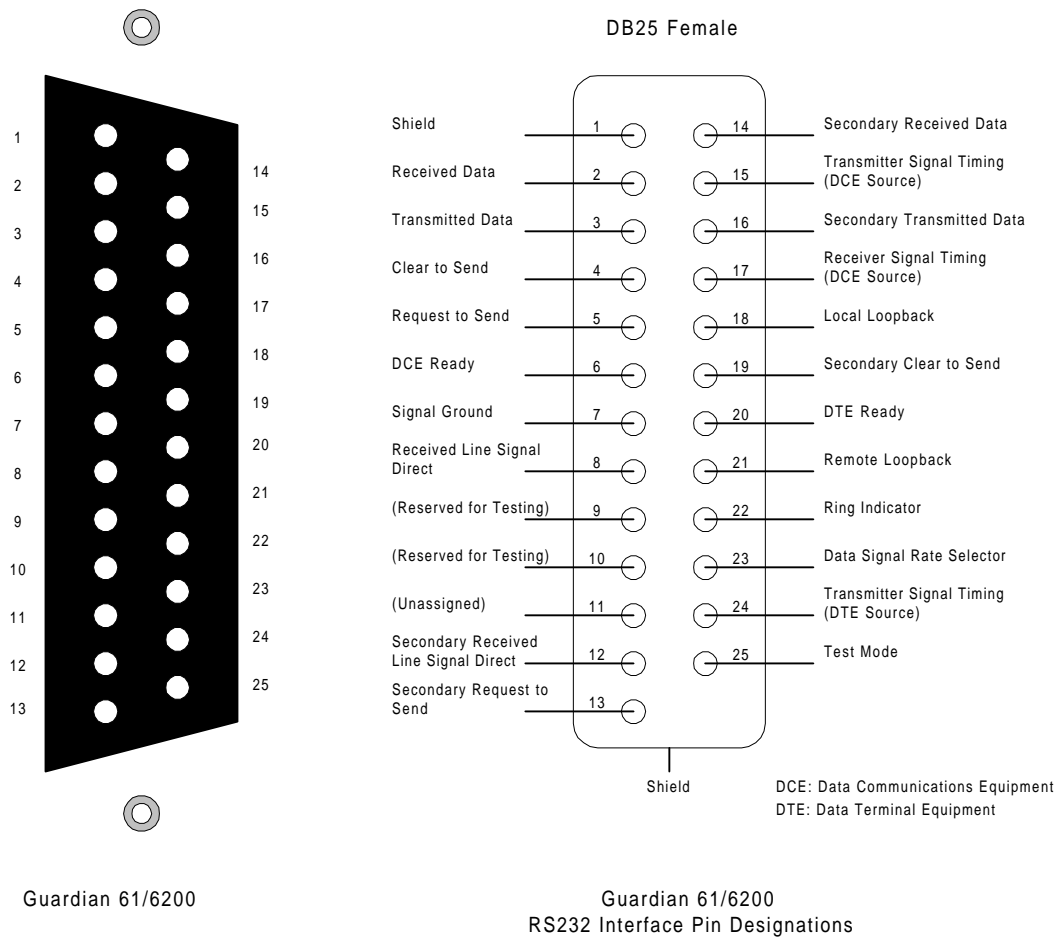

Figure 3-5: RS232 PIN Configuration

3.2.2 RS232 Specifications

Data bits: 8
Stop bits: 1
Parity: None
Baud Rate: 0.3/1.2/2.4/4.8/9.6/19.2 (k) Software Selectable
EOS: CR + LF
Echo: Off

Selecting Baud Rate

Setting the baud rate is done in the initial parameter settings, ¶ 2.12.4.2. Select the initial parameter Remote Settings, then select Baud Rate.

Parameter	Function	Default Value	Rate
Baud Rate	Select Baud Rate	9.6k	0.3 to 19.2 (kbps)

Use the numerical keys to select baud rate then press [ENTER]. Press [PROG] key to exit initial parameter settings.

3.2.3 RS232 Commands

The command set for the RS232 interface is the same as the IEEE-488 interface command set listed in paragraphs 3.3.3 through 3.3.5 of this Instruction Manual.

<p>NOTE CR + LF is the end code for the RS232 Commands.</p>

3.2.4 Sample QuickBasic Program

```
CLS
REM
OPEN "com2:9600,n,8,1,rs" FOR RANDOM AS #2:

PRINT #2, "*idn?"      'get unit identification
FOR j = 1 TO 2000: NEXT j

'determine number of bytes at com port
DO WHILE (LOC(2) = 0)
FOR j = 1 TO 2000: NEXT j
LOOP
' then get the rest of the string
Y = X + LOC(2)
DO WHILE (X <> Y)
Y = X
FOR j = 1 TO 2000: NEXT j
X = LOC(2)
LOOP

'read information at com port
R$ = INPUT$(X, #2)

'print identification to screen
PRINT R$

CLOSE #2
END
```

3.3 IEEE-488 Interface

3.3.1 PIN Configuration

The Guardian 6200 instrument includes an IEEE-488 interface with connection through a blue 24-PIN connector (labeled GPIB) on the rear panel. This interface can be used to connect a system containing a number of instruments and a controller in which each meets IEEE Standard 488.2 (Standard Digital Interface for Programmable Instrumentation). Figure 3-6 illustrates the PIN Configuration of the IEEE-488 interface.

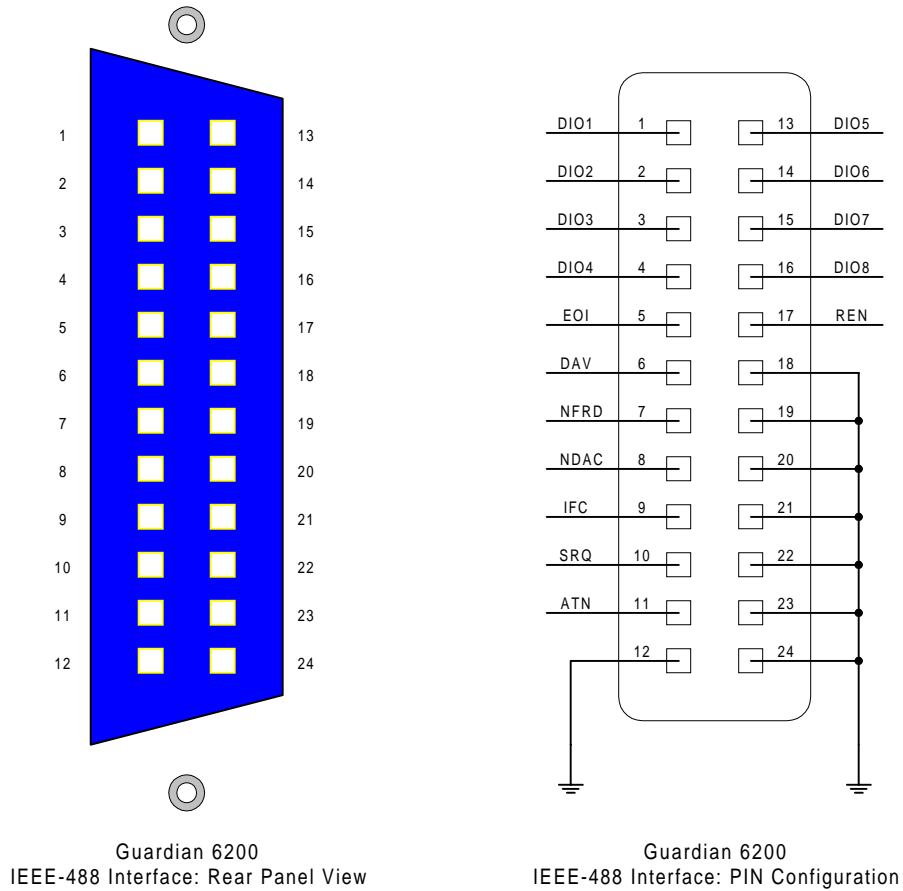

Figure 3-6: IEEE-488 Interface PIN Configuration

3.3.2 IEEE-488 Interface Codes and Messages

The IEEE-488 (GPIB) address is defined in the Initial Parameter Setting mode by selecting [Remote Setting] and [GPIB address]. Refer to paragraph 2.12.4.

The G6200 unit is in a remote control status when the REMOTE LED is ON.

To switch to Local from Remote press the [PROG] key, disabled by LLO message.

The only controls functional under Remote operation is [PROG], which switches to Local and **[STOP]** which resets the unit.

Table 3-1 defines the IEEE-488 interface codes and their function. Table 3-2 defines the IEEE-488 interface messages and their function.

Table 3-1 : IEEE-488 Interface Functions

Code	Function
SH1	Source Handshake
AH1	Acceptor Handshake
T4	Basic Talker Function
L4	Basic Listener Function
SR0	No Service Request Function
RL1	All Remote/Local Function
PP0	No Parallel Poll Function
DC1	All Device Clear Function
DT0	Device Trigger Function
C0	No Controller Functions

Table 3-2 : IEEE-488 Interface Messages

Interface Message	Function	Description
GET	Ground Execute Trigger	Response depends on the *DDT, setting to TEST or STOP
GTL	Go To Local	Switch unit to local
SDC	Selected Device Clear	Reset the unit
LLO	Local Lockout	Disables [PROG] switch to local
IFC	Interface Clear	Reset bus interface

3.3.3 IEEE-488 Interface Commands

The interface function is controlled by ASCII commands which include:

{[command + parameter] ; [command + parameter] + ending code}

The length of the string is 128 characters. It is not necessary to input any sign or space between the command and parameter. Any two commands can be connected by "," and [Ending Code]. Ending Code can be any type in Table 3-3.

Table 3-3 : IEEE-488 Interface Ending Codes

Ending Code
LF
CR + LF
EOI
LF + EOI
CR + LF + EOI

NOTE

The data can be sent out by the IEEE-488 interface to achieve transfer function. The data command is {string message + ending code}. The ending codes are listed in Table 3-3.

NOTE

CR + LF is the ending code for the RS232 Commands.

3.3.4 Listener Functions

Table 3-4 contains the IEEE-488/RS232 Interface command list. This commands are described on the following pages in order of item number.

Table 3-4 : Command List

Item	Command	Parameter	Function
1	STOP	X	stop test
2	TEST	X	start test
3	SHOW (?)	{c}	set testing value
4	STEP (?)	{n}	set Step
5	MODE (?)	{n c}	set test mode
6	SOUR (?)	{f}	set output voltage or current
7	VOLT (?)	{f}	set output voltage
8	CURR (?)	{f}	set output current
9	HILI (?)	{f *}	set High Limit
10	LOLI (?)	{f *}	set Low Limit
11	SARC (?)	{f *}	set ARC
12	BOXN (?)	{n}	Set Box number
13	HICH (?)	{n *}	set High Channel
14	LOCH (?)	{n *}	set Low Channel
15	TIME (?)	{f *}	set the test time
16	RAMP (?)	{f *}	set the voltage rise time
17	OFST (?)	{c}	set offset
18	*SAV	{n}	save the setting value
19	*RCL	{n}	read the setting value
20	CLER	X	clear the memory
21	*IDN (?)	X	check the unit number
22	*DDT (?)	{n c}	set the response to Trigger
23	*TRG	X	execute Trigger command
24	*RST	X	reset the unit
25	DEV(?)	{n}	select the LC Device
26	LINE(?)	{n}	select the LC Line Input
27	POWER(?)	{n}	select the LC Power
28	PWHI(?)	{f *}	set the Power High Limit
29	PWLO(?)	{f *}	set the Power Low Limit

Where

- x: no parameter required
- n: indicates integer
- f: indicates floating
- c: indicates memory mark
- *: indicates the "*" character of ASCII

1. STOP

Stop testing, same as **STOP** on front panel.

2. TEST

Start testing, same as **TEST** on front panel.

3. SHOW (?) {c}

Set and check the testing value, [STATUS] [STEP] [MODE] [SOURCE] [MEASURE] [TIMER] [CHAN] [SAVE]

The command can connect each parameter with "|". Each parameter can be abbreviated. Ex: STA=STATUS, STE=STEP, SO=SOURCE, SA=SAVE

A delay \geq 150 msec should be used between commands during measurements.

4. STEP (?) {n}

Set step number (1 - 10). Set step number first before setting test conditions for that step.

5. MODE (?) {n | c}

Set test mode by number or memory sign.

Mode	Number	Memory Sign
Ground Bond	0	G or GR
AC Hipot	1	A or WA
DC Hipot	2	D or WD
Insulation Resistance	3	I or IR
LC Leakage Current	4	L or LC

If testing mode is changed the test conditions will be cleared to the initial value.

6. SOUR (?) {f}

Set the output voltage of current according to mode selected.

Mode	SOURCE Output
Ground Bond	f = 1 - 30 Amp
AC Hipot	f = 0.01 - 5.0 KV
DC Hipot	f = 0.01 - 6.0 KV
Insulation Resistance	f = 50 - 1000 V
LC Leakage Current	f = 0.05 - 0.4KV

The output voltage for current can be set by SOUR or VOLT or CURR directly. **VOLT or CURR is the recommended method to avoid improper setting** (5 Amp could be interchanged for 5 KV, depending on the MODE selected).

For Ground Bond the high resistance limit is determined by the current setting. The maximum high resistance limit is 510mΩ or $R = 6.3 \text{ V/I}$ (i.e. if the current is 30 Amps the high limit could not exceed 210mΩ).

7. VOLT (?) {f}

Set the output voltage (similar to SOUR). Indicates error 1 if mode is selected for Ground Bond.

8. CURR (?) {f}

Set the output current (similar to SOUR). Indicates error 1 if mode is selected for anything other than Ground Bond.

9. HILI (?) {f | *}

Set the high limit value according to mode selected. * disables the high limit.

Mode	High Limit
Ground Bond	f = 0.1 - 500.0 mΩ
AC Hipot	f = 0.01 - 40.00 mA
DC Hipot	f = 0.01 - 20.00 mA
Insulation Resistance	f = 1 - 9999 MΩ
LC Leakage Current	f = .0001 - 9.999mA
LC (UL544 NP mode)	f = .0001 - 6.000mA

In Hipot mode if the High Limit is smaller than the Low Limit, the low limit is disabled. In IR mode the value can not be smaller than the Low Limit, otherwise error 2 is indicated. In Ground Bond mode the maximum high resistance limit is 510mΩ or $R = 6.3 \text{ V/I}$ (i.e. high resistance limit is 210mΩ for 30 Amps).

10. LOLI (?) {f | *}

Set the low limit value according to mode selected. * disables the low limit.

Mode	Low Limit
Ground Bond	f = 0.1 - 500.0 mΩ
AC Hipot	f = 0.01 - 40.00 mA
DC Hipot	f = 0.01 - 20.00 mA
Insulation Resistance	f = 1 - 9999 MΩ
LC Leakage	f = .0001 - 9.999mA
LC (UL544 NP mode)	f = .0001 - 6.000mA

In Hipot mode the low limit is disabled if greater than High Limit.
 In IR mode the low limit is disabled if greater than the High Limit.
 In Ground Bond mode the low limit can not be set.

11. SARC (?) {f | *}

Set the arc limit value.

* disables the limit.

Mode

Arc Limit

AC Hipot

f = 0.1 - 40.00 mA

DC Hipot

f = 0.1 - 20.00 mA

12. BOXN (?) {n}

Select scan box.

n : 1 – x, x is determined by number preset in initial parameter setting (¶ 2.12).

If more than one scan box is being used, use this command to select the scan box before the high and low channels are set.

13. HICH (?) {n | *}

Set the High Channel, n : 1 - 8.

* disables the limit.

More than one channel is possible (Ex: HICH 1| 3| 5).

14. LOCH (?) {n | *}

Set the Low Channel, n : 1 - 8.

* disables the limit.

More than one channel is possible (Ex: LOCH 1| 3| 5).

Can not be set in Ground Continuity mode.

15. TIME (?) {f | *}

Set the Test Time, f : 0.1 - 999 sec. * disables the timer.

If the disable timer is set to TEST ON, the unit will remain in TEST ON status.

16. RAMP (?) {f | *}

Set the voltage rise time, f : 0 - 99.9 sec. * disables the timer.

Ramp Time is set in AC or DC Hipot Mode only.

17. OFST (?) {c}

Set or examine the offset value.

C : is a word character or abbreviation

“GET” : set a scratch status. “OFF” : close the offset function

“STOP” command makes “OFST GET” = “OFST OFF”.

18. *SAV {n}

Save the test conditions for later recall (up to 10 steps each) in memory location

n : 1 - 50.

19. *RCL (?) {n}

Recall the test conditions that have been saved (up to 10 steps each) in memory location, n : 1 - 50.

20. CLER

Resets the instrument from interface control.

All data is erased except the GPIB address and the RS232 Baud Rate.

21. *IDN ?

Checks the instrument for identification (unit number).

The unit number is displayed after entering the command “QuadTech Guardian 6000”

22. *DDT (?) {n | c}

Determines the response from the interface when the instrument receives TRG or GET command.

“0” or “S”	Stop testing
“1” or “T”	Start testing
“2” or “NS”	Stops testing after receiving “*TRG” or “GET” command and “*DDT” will change to “NT”.
“3” or “NT”	Starts testing after receiving “*TRG” or “GET” command and “*DDT” will change to “NS”.

23. *TRG

Triggers the instrument and functions the same as interface message GET.

This is dependent on the setting of DDT, see 23 above.

24. *RST

Resets the instrument and functions the same as interface message SDC.

25. DEV(?) {n}

Select the LC Device (Human Circuit Model), n : 1 - 5.

1 = UL544NP, 2 = UL544P, 3 = UL1563, 4 = UL2601-1, 5 = UL1950

26. LINE(?) {n}

Select the LC Line Input (Fault Simulation), n : 0 - 3.

0 = Normal, 1 = Reverse, 2 = Single fault normal, 3 = Single fault reverse

27. POWER(?) {n}

Select the DUT Power Monitor, n : 0 - 3.

0 = Voltage, 1 = Current, 2 = VA, 3 = Simulation

28. PWHI(?) {f | *}

Set HIGH Power Limit (for DUT Power Monitor)

f : 0 – 300V, f : 0.001 – 9.999mA, f : 0 – 2200VA * disables the limit.

29. PWLO(?) {f | *}

Set LOW Power Limit (for DUT Power Monitor) f : 0.001 – HIGH Limit

* disables the limit.

3.3.5 Talker Functions

The message of {string + ending code} will be sent when the instrument is assigned as TALKER. The ending code consists of CR+LF+EOI. The string is dependent on the present status. There are several commands with the "?". These commands send the testing value by ASCII string.

- EXAMPLE :
1. Command : mode WD: mode?
: MODE 2 : With Standing DC voltage test mode.
 2. Command : high 1|3|5; high?
:HICH 1|3|5 : High Channel 1,3,5 is ON

All commands will feed back an error message except *RST, *TRG , show and "?". If the error code is not 0 the result will be displayed. Error messages are shown in Table 3-5.

Table 3-5 : IEEE-488 Interface Error Messages

Error Messages
Error 0: Save OK!
Error 1: The command is not valid
Error 2: The parameters are not valid
Error 3: Can not start test
Error 4: Scanner is not connected
Error 5: Channel can not set 0
Error 6: Channel invalid

The TALKER function is completed by SHOW(?) command. The instrument will send back the testing value for the parameter selected. It may check more than one test value by connecting the parameters with "|". Status messages are shown in Table 3-6.

Table 3-6 : IEEE-488 Interface Status Messages

Status Messages
Status 0: Presently in STOP status
Status 1: Presently in TEST status
Status 2: Test complete, condition is PASS
Status 3: Test stop, condition is FAIL
Status 4: Test stop, Hipot arc limit FAIL
Status 5: Test stop, Hipot high limit FAIL
Status 6: Test stop, Hipot low limit FAIL
Status 7: Test stop, IR high limit FAIL
Status 8: Test stop, IR low limit FAIL
Status 9: Test stop, GC high limit FAIL
Status A: Test stop, Charge Low limit FAIL

1. STATUS

To check the present status, with status code.

Output form is : STATUS_X--8 bytes

NOTE : "_" denotes a space

2. STEP

To check the present step.

Output form is : STEP_XX--7 bytes

3. MODE

To check the testing mode.

Output form is : MODE_X--6 bytes

4. SOURCE

To check the output voltage or current.

Output form is :

1) GR Mode	AC_XX.XX_A	
2) AC Mode	AC_X.XXX_kV	
3) DC Mode	DC_X.XXX_kV	
4) IR Mode	DC_XXXX_V	
5) LC Mode	AC_X.XXX_kV	total: 11 bytes

5. MEASURE

To check the tested resistance or current.

Output form is : MEASURE_XXXXX_UU total: 16 bytes
where XXXXX is the measured value
and UU the units.

6. TIMER

To check the test time remaining.

Output form is :

1) TIME_XXX.X	
2) RAMP_XXX.X	total: 10 bytes

7. CHAN

To check the channel status.

Output form is : HICH_X|X||X, LOCH_X|X|.....|X
total: 13 to 41 bytes

8. SAVE

To save the data of each test. The unit can read the data without the SHOW parameter.

9. Meas:all?

To return source and measure data for all steps at the end of the measurement.

Similar to show SOURCE or MEASURE.

Example: How to Display saved results (#8 SAVE)

Write : "SHOW Step|save"

Read : STEP 1

Read : STEP 1

Write : "SHOW mode"

Read : MODE 1

Read : STEP 1 shows step by pressing "SHOW step|save"
"SAVE" parameter can not be used alone

SHOW SAVE will display Error 2

If the instrument is required to display saved item, just use "SHOW?" command
If the instrument is required to display more than one testing value, no matter what the order of parameters, the output will display the following.

[STATUS],[STEP],[MODE],[SOURCE],[MEASURE],[TIMER],[CHAN]

Any two parameters are separated by a ","

Example: Write: "SHOW STEP|STATUS|MODE"

Read: STATUS 2, STEP 1, MODE 1

The string length sent by SHOW may not be more than 107 bytes (including ending code).

3.3.6 Sample QuickBASIC Program

```
REM $INCLUDE: 'qbdecl.bas'
'declarations
ADAP$ = "GPIB0": G6000$ = "DEV3": V% = 1
W% = 0: C$ = SPACE$(50): d$ = SPACE$(50): C1$ = SPACE$(50): D1$ =
SPACE$(50)
STAT$ = SPACE$(50)

'find IEEE card and G6000
CALL IBFIND(ADAP$, GPIB0%)
CALL IBFIND(G6000$, G6000%)

CLS 'clear screen

'read identification from g6000
CALL IBWRT(G6000%, "*IDN")
CALL IBRD(G6000%, D1$)
PRINT D1$

'open a file to store data and status to
20
PRINT "FILE NAME TO STORE RESULT (less than 8 characters)"
INPUT NAMES$
IF LEN(NAMES$) = 0 THEN NAMES$ = "DATA"
IF LEN(NAMES$) > 8 THEN GOTO 20
NAMES$ = NAMES$ + ".TXT"
OPEN NAMES$ FOR APPEND AS #1

'ask user for mode, voltage, current, ramp and test time
50
PRINT "MODE 1 = AC, 2 = DC"
INPUT MODE$
IF MODE$ = "" OR MODE$ > "2" OR MODE$ < "1" THEN GOTO 50 'check mode is
AC/DC hipot
100
PRINT "INPUT VOLTAGE IN kV"
INPUT VOLT$
IF VOLT$ = "" OR VOLT$ > "5" THEN GOTO 100 'check voltage is in range
200
PRINT "HIGH CURRENT LIMIT IN mA"
INPUT CURR$
IF CURR$ = "" OR CURR$ > "40" THEN GOTO 200 'check current is in range
PRINT "RAMP TIME IN seconds"
INPUT RAMP$
```

```

300
PRINT "TEST TIME IN seconds"
INPUT TIM$
IF TIM$ = "" OR TIM$ > "999.9" THEN GOTO 300 'check time is in range

'configure g6000
SET$ = "STEP1;MODE" + MODE$ + ";SOUR " + VOLT$ + ";HILI" + CURR$ +
";RAMP" + RAMP$ + ";TIME" + TIM$
CALL IBWRT(G6000%, SET$)          'send string to g6000
REM CALL IBRD(G6000%, C$)        'read status of g6000

'perform a measurement
CALL IBWRT(G6000%, "STOP") 'make sure unit is in stop mode
CALL IBRD(G6000%, C$)      'read status
PRINT C$
CALL IBWRT(G6000%, "TEST") 'start measurement
FOR I = 1 TO 500
NEXT I
CALL IBWRT(G6000%, "SHOW STATUS") 'check status of unit
CALL IBRD(G6000%, STAT$)
WHILE VAL(MID$(STAT$, 8, 1)) = 1 'loop while status is testing
    CALL IBWRT(G6000%, "SHOW STATUS")
    CALL IBRD(G6000%, STAT$)
    PRINT STAT$
WEND

'get data from G6000
CALL IBWRT(G6000%, "SHOW SOURCE|MEASURE") 'ask for voltage and current
levels
CALL IBRD(G6000%, d$) 'read current and voltage levels
PRINT "DATA IS: "; d$ 'output data to the screen
PRINT #1, d$ + STAT$ + TIME$ + " " + DATE$ 'store data and status to open file
CLOSE #1

END

```

3.4 Printer Interface

An optional Printer Interface is available for the Guardian 6200 instrument. The Printer interface takes the place of the IEEE-488 interface and is factory installed when the unit is ordered. Connection is through the black 25-PIN connector labelled 'GPIB' on the rear panel of the G6200 unit. Figure 3-7 illustrates the Printer interface PIN Configuration.

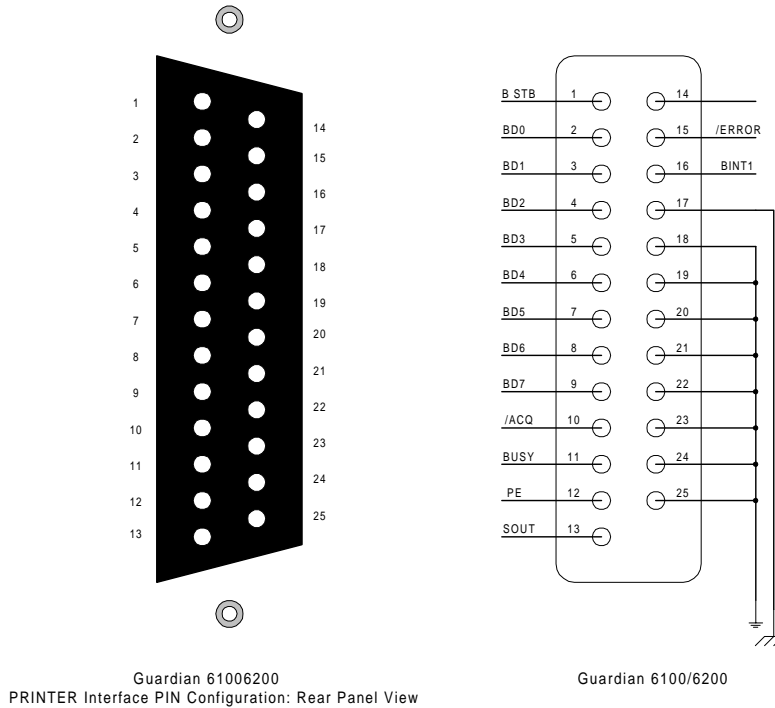

Figure 3-7: Printer Interface PIN Configuration

A typical printer output for a 3-Step Pass is illustrated below followed by Step 2 which is designated 'Fail for Low'.

STEP-01 Pass 0.0s
0.998kV WAC 0.018mA

STEP-02 Pass 0.0s
1.998kV WDC 0.001mA

STEP-03 Pass 0.0s
0.2V LC 0.003mA

STEP-01 Pass 0.0s
0.998kV WAC 0.018mA

STEP-02 Low 0.0s
1.998kV WDC 0.001mA

3.5 Scanner Interface

3.5.1 Scanner Accessories

An optional Scanner Interface is available for the Guardian 6200 instrument. The Scanner interface is factory installed when the unit is ordered. Connection is through the black 25-PIN connector labeled 'SCAN' on the rear panel of the Guardian 6200 instrument. The Guardian 6200 unit may be used with an external scan unit for multi-point grounding and hipot tests. Table 3-7 displays the scanner accessories available for the G6200 unit.

Table 3-7 : Guardian 6200 Scanner Accessories

Item	Qty	QT P/N
25 pin interconnect cable (G6200 to Scanner)	1	G17
Hipot Test Lead Set (G6200 to Scanner I/P)		
HV plug to sheathed banana plug (red)	1	G18
Banana Plug (with retaining bracket) to sheathed banana plug (black)	1	G19
Hipot Scan Clip Leads (Scanner to front panel outputs of DUT)		
Sheathed banana plug (orange) to alligator clip (red)	8	G21
GC Interconnect Cable (G6200 output to Scanner rear panel GC input)		
Banana plug/lug (red/black) to banana plug/lug (red/black)	1	G20*
GC Scan Clip Lead Set (Scanner rear panel GC outputs to DUT)		
Large alligator clips (red/black) to banana plug/lug (red/black)	4	G15*
Scanner to Scanner Banana Plug to Banana Plug Cable set: 1 Black, 1 Red	2	G24
Scan card for Guardian 6200	1	
Corded Product Adapter (115V) for 6000-04 Line Leakage Scanner	1	G30
500VA Isolation Transformer for 6000-04 Line Leakage Scanner	1	G31
1000VA Isolation Transformer for 6000-04 Line Leakage Scanner	1	G32

* Included with GC Scanner only (Guardian 6000-01, 6000-02, 5000-02 and 5000-04).

3.5.2 Internal Scanner Connection

No installation of a scanner card is necessary with the Guardian 6200 Production Safety Analyzer. The instrument contains a 6000-04 scan unit and applicable hardware that is factory installed when the purchase order is placed.

3.5.3 External Scanner Connections

Before connecting an external 5000 scanner to the Guardian 6200 or connecting devices for test, **press the [STOP] key** and make sure the red **DANGER** light is **OFF**. Figures 3-8 and 3-9 illustrate the connection of the G6200 unit to an external scanner.

The G17 25-PIN SCAN control cable is connected from the G6200 rear panel SCAN connector to the 5000-01 rear panel SCAN I/P connector.

The G18 lead set connects the HV terminals. The white 'Star' plug is connected to the G6200 front panel HV output terminal and the red banana plug is connected to the 5000-01 front panel HV I/P terminal.

The G19 lead set connects the GND terminals. The black banana plug with retaining bracket is connected to the G6200 front panel GND output terminal and the black banana plug is connected to the 5000-01 front panel LOW I/P terminal.

Interconnect the Rear Panel Ground Lugs (Chassis Ground, silver screw/banana plug) using a banana to banana cable or banana to spade cable. This assures that the scanner(s) retains connection to earth ground.

WARNING
THE REAR PANEL GROUND LUGS ON ALL INSTRUMENTS (Guardian 6100/6200 and Scanners) MUST BE INTERCONNECTED

3.5.4 External Scanner Programming

The Guardian 5000 Series external scanners have 16 indicators (8 high, 8 low) on the scanner front panel. During a test these indicate which are programmed for the High Voltage or Low connections. Connections for high voltage are indicated in red and low in green. When the scanner and Guardian 6200 are connected (25 pin interconnect cable) the instrument will accept entry of scanner connections. A **High** or **Low** entry is made during the programming process preceding the entry of a test voltage. It is possible to have one or multiple entries for scanner connections, i.e. if 1 ,2 and 3 are entered for the High connection all three outputs will be connected to the High Voltage terminal during the test.

Figure 3-8 illustrates the connection of a 5000-02 external scanner to a G6200 instrument using the rear output terminals for a ground bond test Programming instructions for this specific example are included.

Example Connection of 5000-02 to G6200 for Ground Bond Test

Figure 3-8 illustrates the connection of the 5000-02 external scanner to the 6200 instrument for a ground bond test on multiple points of a DUT chassis. Connection is made to the rear output terminals in this example. Connection could just as well be made to the front output terminals because this is not a leakage current test.

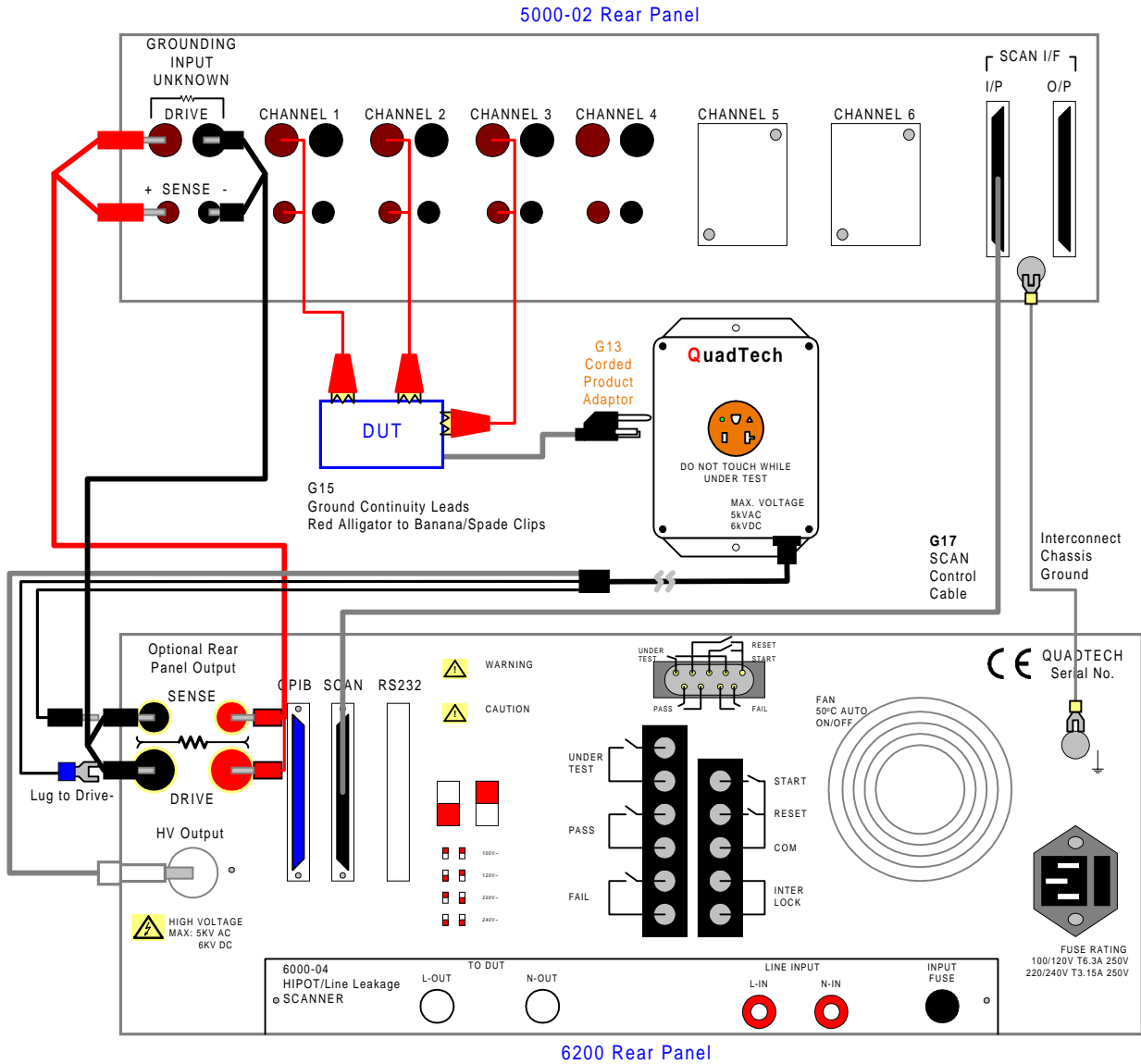

Figure 3-8: Guardian 6200 Connection to 5000-02 External Scanner (GR Test)

Programming Instructions for Ground Bond Testing using 5000-02 and G6200

At times it is desirable to perform the ground bond test on multiple points of the chassis. This example illustrates how to perform a ground bond test on 3 external points followed by an AC hipot test using the G13, 5000-02 and the G6200.

Press [PROG]

Select Step = 1
1-99 (UP/DOWN)

Select Test STEP. Press UP or DOWN arrow to enter test step =1

Press [ENTER]

Select Mode = GR
Press UP/DOWN

Select Test MODE. Press UP arrow to display GR

Press [ENTER]

Current = 25.00A
1 - 30A

Select CURRENT. Press [2] [5] [.] [0] to enter test current = 25A

Press [ENTER]

High Limit = 100.0mΩ
0.1 - 510mΩ

Select HIGH Limit (mΩ). Press [1] [0] [0] [.] [0] to enter High Limit = 100mΩ

Press [ENTER]

Low Limit = Disable
0.1-510mΩ 0=Disable

Select LOW Limit (mΩ)

Ω

Press [ENTER]

Test Time = _10.0s
0 -999s 0 = Disable

Select Test TIME (sec). Press [1] [.] [0] to enter Test Time = 1sec

Press [ENTER]

Select Step = 2
1-99 (UP/DOWN)

GR TEST SETUP IS COMPLETE. Select Step = 2. Continue with AC hipot test.

Programming Instructions – Continued

Test STEP = 2.

Press [ENTER]

Select Mode = WAC
Press UP/DOWN

Select Test MODE. Press UP arrow to display WAC

Press [ENTER]

High = Disable
Box-1 Channel (1-1)

Select Scanner HIGH Channels. We will not be using the scanner for hipot, Press [Off] to disable

Press [ENTER]

High = Disable
Box-2 Channel (1-8)

Select Scanner HIGH Channels. We will not be using the scanner for hipot, Press [Off] to disable

Press [ENTER]

Low = Disable
Box-2 Channel (1-8)

Select Scanner LOW Channels. We will not be using the scanner for hipot, Press [Off] to disable

Press [ENTER]

Voltage = 1.200kV
0.05 - 5.00 kV

Select Test Voltage. Press [1][.][2][0] to enter voltage = 1.2kV

Press [ENTER]

High Limit = 1.500mA
0.001 40 mA

Select High Limit (mA). Press [1][.][5][0] to enter high current limit = 1.5mA

Press [ENTER]

Low Limit = Disable
0-40mA 0=Disable

Select Low Limit (mA)

Press [ENTER]

Arc Limit = Disable
0-40mA 0=Disable

Select Arc Limit. Press [0] to disable arc limit

Press [ENTER]

Test Time = 10.0s
0 - 999s 0=Disable

Select Test Time (sec). Press [3][.][0] to enter time = 3.0sec

Press [ENTER]

Ramp Time = 1.0s
0 - 999s 0=Disable

Select Ramp Time (sec). Press [1][.][0] to enter time = 1.0sec

AC Hipot TEST SETUP IS COMPLETE. Press [Prog] to exit programming function.

Notes on Scanner Programming

The Guardian 6200 instrument will look for the first scanner to be the internal scanner (6000-04). Scanners #2-8 are external scanners (5000-01, -02, -03 or -04). When programming scanner connections the scanner number (1 through 8) is shown on the G6200 display.

When using **one** scanner, the scan box channels 1-8 can be programmed high or low prior to entering the test voltage. Use the numerical keys and enter the high scan channels. Press [ENTER] to accept. Use the numerical keys and enter the low scan channels. Press [ENTER] to accept.

When using **more than one** scanner, the Initial Parameter setting: “Scan No” must be setup for the total number of scanners connected. Refer to paragraph 2.12.

Press [ENTER] [6] [2] [0] [0] to enter Initial Parameter setting mode.

Press [→] [↑] [↑] to enter “Scan No” screen.

Press numerical keys to enter the total number of scanners from 1 to 8.

Press [ENTER] to accept.

Press [PROG] to exit Initial Parameter setting mode.

Connection of up to 8 scanners for hipot or IR testing is possible for a total of 64 channels. Ground continuity testing is limited to 1 scanner (5000-02) for a total of 4 channels. When programming scanner connections the scanner number (1 through 8) is shown on the display.

NOTE

If stacking scanners, the HV only scanner(s) must be first in the chain followed by the GC scanner(s) for proper operation.

NOTE

When the scanner is programmed for multiple connections in the same test step the DUT's are connected in parallel (as shown in Figure 3-9). To test several devices independent from each other, requires an individual test step (1 to 10) for each. Refer to paragraphs 2.3 – 2.7.

For more programming examples, refer to QuadTech Application Note P/N 035116, “Guardian 6000 Series Scanner Connections”. For free access to the application note library, visit <http://www.quadtech.com>.

Figure 3-9 illustrates the connection of two external 5000-01 scanners to the G6200 front panel output terminals for a Hipot or IR test.

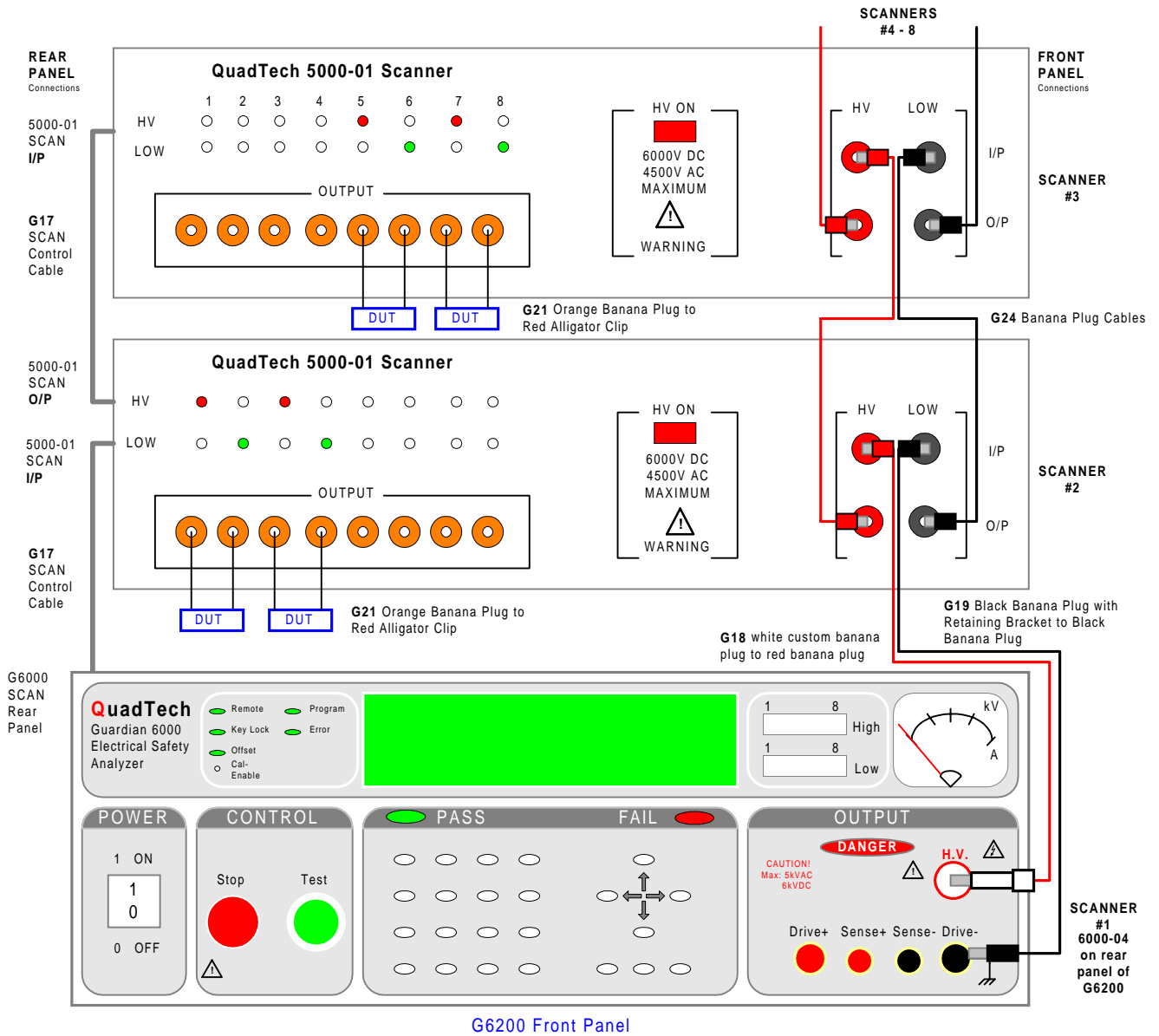

Figure 3-9: Guardian 6200 Connection to 5000-01 Multiple External Scanners (AC/DC Hipot & Insulation Resistance Tests)

Section 4 : Service & Calibration

4.1 General

Our warranty (at the front of the manual) attests the quality of materials and workmanship in our products. If malfunction should be suspected, or other information be desired applications engineers are available for technical assistance. Application assistance is available in the U.S. by calling 978-461-2100 and asking for Applications Support. For support outside of the United States please contact your local QuadTech distributor.

4.2 Instrument Return

Before returning an instrument to QuadTech for service please call our **Customer Care Center (CCC)** at **800-253-1230** for Return Material Authorization (RMA). It will be necessary to include a Purchase Order Number to insure expedient processing, although units found to be in warranty will be repaired at no-charge. For any questions on repair costs or shipment instructions please contact our CCC Department at the above number. To safeguard an instrument during storage and shipping please use packaging that is adequate to protect it from damage, i.e., equivalent to the original packaging and mark the box "Delicate Electronic Instrument". Return material should be sent freight prepaid, to:

QuadTech, Inc.
5 Clock Tower Place, 210 East
Maynard, Massachusetts 01754

Attention: RMA #

Shipments sent collect cannot be accepted.

4.3 Calibration

Calibration of the Guardian 6200 instrument is recommended on an annual basis. If the unit is returned to QuadTech for factory calibration refer to paragraph 4.2 for instructions. Using the calibration procedure in paragraph 4.3.1, the instrument can be calibrated by a qualified service person if traceable calibration equipment and standards are available. **The instrument should be powered up for a minimum of 1 hour before calibration to ensure maximum stability.**

Table 4-1 : Calibration Equipment

Equipment	Parameter	Requirements
AC/DC High Voltage Voltmeter		Measure Range : 0 to 6KV, 0.1% accuracy
AC/DC Current Meter		Measure Range : 0 to 40mA, 0.1% accuracy
Fluke 5500 Calibrator	Leakage Current	V/A Source: 0-300V/0-10A
1GΩ Resistance Standard	IR Resistor	250V
100MΩ Resistance Standard	IR Resistor	500V
10MΩ Resistance Standard	IR Resistor AC & DC Current	500V & 1000V 1200V, 0.1mA, .25W
480KΩ Resistance Standard	AC & DC Current	1200V, 3mA, 50W
250KΩ Resistance Standard	ARCing	1250V, 5mA, 5W
80KΩ Resistance Standard	DC Current	1200V, 15mA, 100W
45KΩ Resistance Standard	AC Current	1200V, 25mA, 200W
100mΩ Resistance Standard	Ground Continuity	200W
50mΩ Resistance Standard	Ground Continuity	
10mΩ Resistance Standard	Ground Continuity	

4.3.1 Calibration Procedure

Table 4-2 contains the calibration parameters for the Guardian 6200 unit.

Table 4-2 : Calibration Parameters

TEST		RANGE		CAL. POINT
Voltage Calibration				
CAL	ACV	5kV	OFST	0.050 KV
CAL	ACV	5kV	FULL	4.000 KV
CAL	DCV	6kV	OFST	0.050 KV
CAL	DCV	6kV	FULL	4.000 KV
CAL	IR	1kV	OFST	0.050 KV
CAL	IR	1kV	FULL	1.000 KV
Current Calibration				
CAL	ACA	3mA	OFST	0.120 mA
CAL	ACA	3mA	FULL	2.500 mA
CAL	ACA	40mA	OFST	2.50 mA
CAL	ACA	40mA	FULL	25.00 mA
CAL	DCA	3mA	OFST	0.120 mA
CAL	DCA	3mA	FULL	2.500 mA
CAL	DCA	20mA	OFST	2.50 mA
CAL	DCA	20mA	FULL	12.00 mA
Ground Continuity Calibration				
CAL	GRA	30A	OFST	3.00 A
CAL	GRA	30A	FULL	25.00 A
CAL	GRV	8V	OFST	3.00A
CAL	GRV	8V	FULL	30.00A
WAC and WDC ARCing Calibration				
CAL	AC ARC	40mA	Arc	5.00mA
CAL	DC ARC	20mA	Arc	5.00mA

Table 4-2 : Calibration Parameters (Continued)

Leakage Current Current Meter Calibration				
CAL	LC	1V	OFST	0.600mA
CAL	LC	1V	FULL	0.600mA
CAL	LC	10V	OFST	6.000mA
CAL	LC	10V	FULL	6.000mA
Leakage Current Power Meter Calibration				
CAL	LCV	300V	OFST	6.000mA
CAL	LCV	300V	FULL	6.000mA
CAL	LCA	1A	OFST	6.000mA
CAL	LCA	1A	FULL	6.000mA
CAL	LCA	10A	OFST	6.000mA
CAL	LCA	10A	FULL	6.000mA
IR Resistor Mode Calibration				
CAL	RnG0	1.00 GΩ	IRR	Range 1 to 1.00GΩ
CAL	RnG1	100.0 MΩ	IRR	Range 2 to 100.0MΩ
CAL	RnG2	10.0 MΩ	IRR	Range 3 to 10.0MΩ
CAL	RnG3	1.00MΩ	IRR	Range 4 to 10.0MΩ

To Enable Calibration:

With the instrument in standby status ([Stop] button previously pressed and no lights flashing) remove the front panel calibration seal and push (using tip of small screwdriver) the recessed switch through the hole in the front panel labeled Cal-Enable (to the IN position).

Press [BUTTON]:

[ENTER] [7] [9] [3] [1]

[Off]

[PROG] (to enter Calibration)

Display Reads:

Calibrate is ON
Press OFF key.

Calibrate is Test
Press OFF key.

Cal ACV 5kV Offset
0.050kV

NOTE

Pressing the [↑] key at any time during calibration permits the operator to scroll through the calibration steps.

The [OFF] key enters the operator into that particular calibration step.

The [STOP] key accepts the calibration value.

4.3.2 AC Voltage Calibration

Connect the AC voltmeter between the **HV** and **DRIVE- OUTPUT** terminals.

Press [BUTTON]:



[Off]

[STOP] [TEST]

(Read Voltage from voltmeter. Example: 0.062kV)

[0] [.] [0] [6] [2] [ENTER]

[STOP]



[Off]

[STOP] [TEST]

(Read Voltage from voltmeter. Example: 4.052kV)

[4] [.] [0] [5] [2] [ENTER]

[STOP]

Display Reads:

Cal ACV 5kV Offset 0.050kV

Step-01	0.0s
0.050kV WAC	0.500mA

Step-01	30.0s
---------	-------

Step-01	30.0s
---------	-------

Step-01	0.0s
0.050kV WAC	0.500mA

Cal ACV 5kV Full 4.000kV

Step-01	0.0s
4.000kV WAC	0.500mA

Step-01	30.0s
---------	-------

Step-01	30.0s
---------	-------

Step-01	0.0s
4.000V WAC	0.500mA

4.3.3 DC Voltage Calibration

Connect the DC voltmeter between the **HV** and **DRIVE- OUTPUT** terminals.

Press [BUTTON]:



[Off]

[STOP] [TEST]

(Read Voltage from voltmeter. Example: 0.062kV)

[0] [.] [0] [6] [2] [ENTER]

[STOP]



[Off]

[STOP] [TEST]

(Read Voltage from voltmeter. Example: 4.052kV)

[4] [.] [0] [5] [2] [ENTER]

[STOP]

Display Reads:

Cal DCV 6kV Offset 0.050kV

Step-01	0.0s
0.050kV WDC	0.500mA

Step-01	30.0s
---------	-------

Step-01	30.0s
---------	-------

Step-01	0.0s
0.050kV WDC	0.500mA

Cal DCV 6kV Full 4.000kV

Step-01	0.0s
4.000kV WDC	0.500mA

Step-01	30.0s
---------	-------

Step-01	30.0s
---------	-------

Step-01	0.0s
4.000V WDC	0.500mA

4.3.4 IR Voltage Calibration

Connect the DC voltmeter between the **HV** and **DRIVE- OUTPUT** terminals.

Press [BUTTON]:



[Off]

[STOP] [TEST]

(Read Voltage from voltmeter. Example: 0.062kV)

[0] [.] [0] [6] [2] [ENTER]

[STOP]



[Off]

[STOP] [TEST]

(Read Voltage from voltmeter. Example: 1.052kV)

[1] [.] [0] [5] [2] [ENTER]

[STOP]

Display Reads:

Cal IRV 1kV Offset 0.050kV

Step-01	0.0s
0.050kV IR	1.0M Ω

Step-01	30.0s
---------	-------

Step-01	30.0s
---------	-------

Step-01	0.0s
0.050kV IR	1.0M Ω

Cal IRV 1kV Full 1.000kV

Step-01	0.0s
1.000kV IR	1.0M Ω

Step-01	30.0s
---------	-------

Step-01	30.0s
---------	-------

Step-01	0.0s
1.000kV IR	1.0M Ω

4.3.5 AC Current Calibration

Connect a load resistor (10 M Ω) between the **HV OUTPUT** terminal of the Guardian 6100 and the High terminal of the AC ammeter. Connect the Low terminal of the AC ammeter to the **DRIVE-** terminal (black) of the Guardian 6200.

ACA 3mA Offset & Full:

Press [BUTTON]:



[Off]

[STOP] [TEST]

(Read Current from current meter. Example: 0.124mA)

[0] [.] [1] [2] [4] [ENTER]

[STOP]

(Change Load Resistor to 480k Ω >50W)



[Off]

[STOP] [TEST]

(Read Current from current meter. Example: 2.903mA)

[2] [.] [9] [0] [3] [ENTER]

[STOP]

Display Reads:

Cal ACA 3mA Offset 0.120mA

Step-01	0.0s
1.200kV WAC	2.999mA

Step-01	30.0s
---------	-------

Step-01	30.0s
---------	-------

Step-01	0.0s
1.200kV WAC	2.999mA

Cal ACA 3mA Full 2.500mA

Step-01	0.0s
1.200kV WAC	2.999mA

Step-01	30.0s
---------	-------

Step-01	30.0s
---------	-------

Step-01	0.0s
1.200kV WAC	2.999mA

ACA 40mA Offset & Full:

Press [BUTTON]:



[Off]

[STOP] [TEST]

(Read Current from current meter. Example: 2.413mA)

[2] [.] [4] [1] [3] [ENTER]

[STOP]

(Change Load Resistor to 45k Ω , >200W)



[Off]

[STOP] [TEST]

(Read Current from current meter. Example: 24.50mA)

[2] [4] [.] [5] [0] [ENTER]

[STOP]

Display Reads:

Cal ACA 40mA Offset 2.50mA

Step-01	0.0s
1.200kV WAC	30.00mA

Step-01	30.0s
---------	-------

Step-01	30.0s
---------	-------

Step-01	0.0s
1.200kV WAC	30.00mA

Cal ACA 40mA Full 25.00mA

Step-01	0.0s
1.200kV WAC	30.00mA

Step-01	30.0s
---------	-------

Step-01	30.0s
---------	-------

Step-01	0.0s
1.200kV WAC	30.00mA

4.3.6 DC Current Calibration

Connect a load resistor (10 M Ω) between the **HV OUTPUT** terminal of the Guardian 6100 and the High terminal of the DC ammeter. Connect the Low terminal of the DC ammeter to the **DRIVE-** terminal (black) of the Guardian 6200.

DCA 3mA Offset & Full:

Press [BUTTON]:



[Off]

[STOP] [TEST]

(Read Current from current meter. Example: 0.124mA)

[0] [.] [1] [2] [4] [ENTER]

[STOP]

(Change Load Resistor to 480k Ω , >50W)



[Off]

[STOP] [TEST]

(Read Current from current meter. Example: 2.413mA)

[2] [.] [4] [1] [3] [ENTER]

[STOP]

Display Reads:

Cal DCA 3mA Offset
0.120mA

Step-01	0.0s
1.200kV WDC	2.999mA

Step-01	30.0s
---------	-------

Step-01	30.0s
---------	-------

Step-01	0.0s
1.200kV WDC	2.999mA

Cal DCA 3mA Full
2.500mA

Step-01	0.0s
1.200kV WDC	2.999mA

Step-01	30.0s
---------	-------

Step-01	30.0s
---------	-------

Step-01	0.0s
1.200kV WDC	2.999mA

DCA 20mA Offset & Full:

Press [BUTTON]:



[Off]

[STOP] [TEST]

(Read Current from current meter. Example: 2.503mA)

[2] [.] [5] [0] [3] [ENTER]

[STOP]

(Change Load Resistor to 80k Ω , >100W)



[Off]

[STOP] [TEST]

(Read Current from current meter. Example: 14.82mA)

[1] [4] [.] [8] [2] [ENTER]

[STOP]

Display Reads:

Cal DCA 20mA Offset 2.50mA

Step-01	0.0s
1.200kV WDC	15.00mA

Step-01	30.0s
---------	-------

Step-01	30.0s
---------	-------

Step-01	0.0s
1.200kV WDC	15.00mA

Cal DCA 20mA Full 12.00mA

Step-01	0.0s
1.200kV WDC	15.00mA

Step-01	30.0s
---------	-------

Step-01	30.0s
---------	-------

Step-01	0.0s
1.200kV WDC	15.00mA

4.3.7 Ground Continuity Calibration

Connect a 4 terminal load resistor (10m Ω) between the Guardian 6200 (Drive+/Drive-) and (Sense+/Sense-) OUTPUT terminals. Connect an AC voltmeter to Sense+ and Sense- of the load resistor.

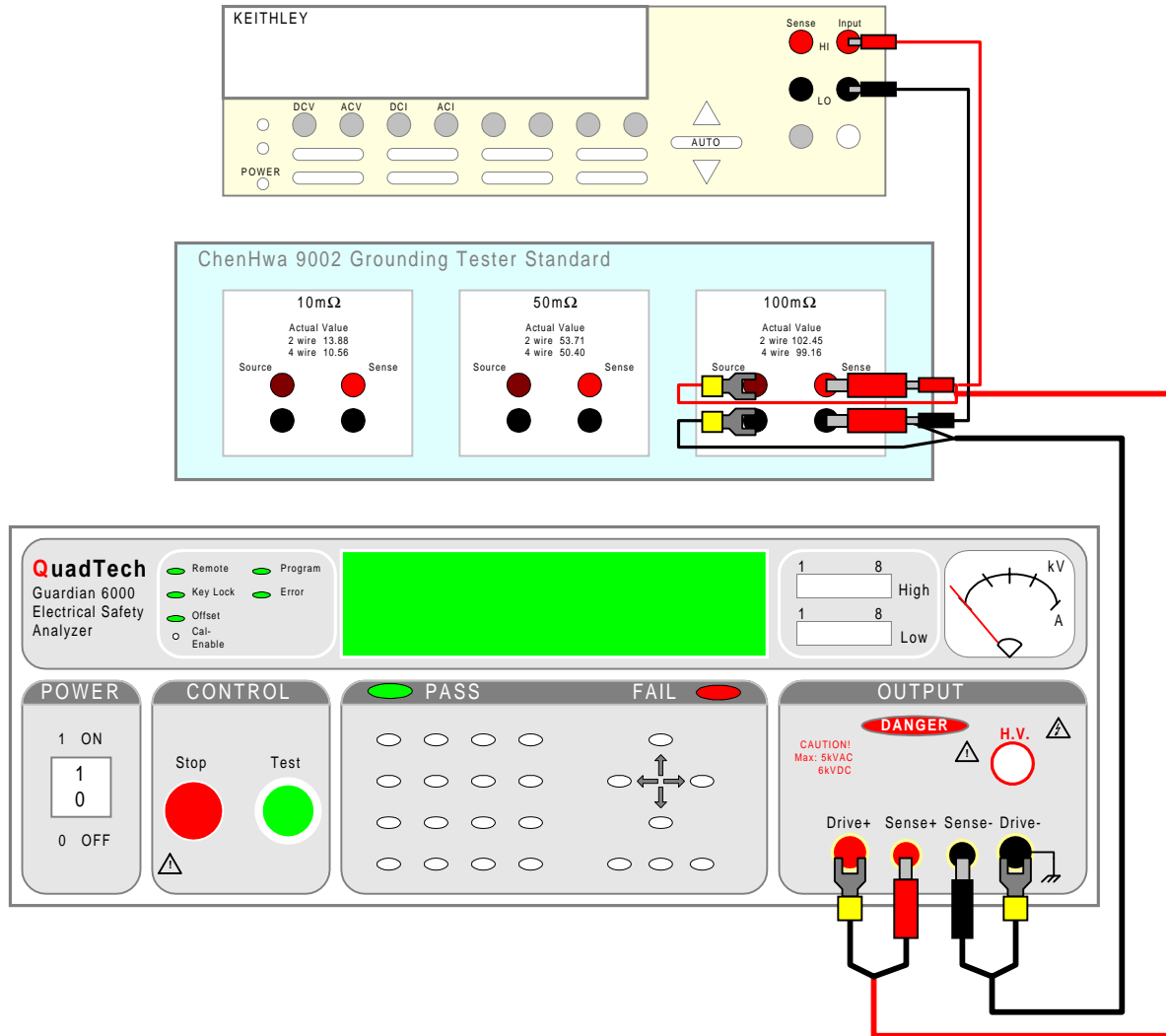

Figure 4.1: GC Calibration Configuration

GRA 30A Offset & Full

Press [BUTTON]:



[Off]

[STOP] [TEST]

(Read Voltage from voltmeter. Calculate current $I = V/R$. Example: 2.897A)

[2] [.] [8] [9] [7] [ENTER]

[STOP]

(Change Load Resistor to 100mΩ)



[Off]

[STOP] [TEST]

(Read Voltage from voltmeter. Calculate current $I = V/R$. Example: 24.87A)

[2] [4] [.] [8] [7] [ENTER]

[STOP]

Display Reads:

Cal GRA 30A Offset 3.00 A

Step-01	0.0s
3.00 A GRA	200.0 m Ω

Step-01	30.0s
---------	-------

Step-01	30.0s
---------	-------

Step-01	0.0s
3.00 A GRA	200.0 m Ω

Cal GRA 30A Full 25.00 A

Step-01	0.0s
25.00 A GR	200.0 m Ω

Step-01	30.0s
---------	-------

Step-01	30.0s
---------	-------

Step-01	0.0s
25.00 A GR	200.0 m Ω

GRV 8V Offset & Full:

Change the load resistor to 50mΩ and connect an AC voltmeter to the Sense + and Sense – terminals of the load resistor.

Press [BUTTON]:



[Off]

[STOP] [TEST]

(Read Voltage from voltmeter. Input voltage value to 6100. Example: 3.015 V)

[3] [.] [0] [1] [5] [ENTER]

[STOP]

(Change Load Resistor to 100mΩ)



[Off]

[STOP] [TEST]

(Read Voltage from voltmeter. Input voltage to G6100. Example: 30.05 V)

[3] [0] [.] [0] [5] [ENTER]

[STOP]

Display Reads:

Cal GRV 8V Offset 0.300 V

Step-01 0.0s 3.00 A GR 200.0 m Ω

Step-01 30.0s

Step-01 30.0s

Step-01 0.0s 3.00 A GR 200.0 m Ω

Cal GRV 8V Full 3.000 V

Step-01 0.0s 30.00 A GR 200.0 m Ω

Step-01 30.0s

Step-01 30.0s

Step-01 0.0s 30.00 A GR 200.0 m Ω

4.3.8 WAC and WDC ARcing Calibration

Connect a load resistor of 250kΩ (5 watt). Connect an AC current meter.

Note : arcing calibration range value is 0.1 – 9.9mA. During calibration the arcing value is changed to ARcing NG.

AC ARC 40mA & DC ARC 20mA:

Press [BUTTON]:



[Off]

[STOP] [TEST]

(Read Current from current meter. Example: 5.049mA)

[5] [.] [0] [4] [9] [ENTER]

[STOP]



[Off]

[STOP] [TEST]

(Read Current from current meter. Example: 5.051mA)

[5] [.] [0] [5] [1] [ENTER]

[STOP]

Display Reads:

Cal AC ARC 40mA 5.00mA

Step-01 0.0s 1.250kV WAC 10.00mA

Step-01 30.0s

Step-01 30.0s

Step-01 0.0s 1.250kV WAC 10.00mA

Cal DC ARC 20mA 5.00mA

Step-01 0.0s 1.250kV WDC 10.00mA

Step-01 30.0s

Step-01 30.0s

Step-01 0.0s 1.250kV WDC 10.00mA

4.3.9 Leakage Current Current Meter Calibration

4.3.9.1 LC 1V Offset & Full:

Connect the Fluke 5500 calibrator to the 6200 rear panel **L-IN** and **Drive-** terminals. Program the Fluke 5500 for voltage levels of 0.08V (1V Offset) and 0.8V (1V Full).

Press [BUTTON]:



[Off]

[STOP] [TEST]

(Read Voltage from voltmeter. Example: 0.08V)

[0] [.] [0] [8] [ENTER]

[STOP]



[Off]

[STOP] [TEST]

(Read Voltage from voltmeter. Example: 0.8V)

[0] [.] [8] [ENTER]

[STOP]

Display Reads:

Cal	LC	1V	Offset	
0.08 V				

Step-01	D1	LO	0.0s	
Disable	LC	599.0	uA	

Step-01		30.0s		
---------	--	-------	--	--

Step-01		30.0s		
---------	--	-------	--	--

Step-01	D1	LO	0.0s	
Disable	LC	599.0	uA	

Cal	LC	1V	Full	
0.8 V				

Step-01	D1	LO	0.0s	
Disable	LC	599.0	uA	

Step-01		30.0s		
---------	--	-------	--	--

Step-01		30.0s		
---------	--	-------	--	--

Step-01	D1	LO	0.0s	
Disable	LC	599.0	uA	

4.3.9.2 LC 10V Offset & Full:

Connect the Fluke 5500 calibrator to the 6200 rear panel **L-IN** and **Drive-** terminals. Program the Fluke 5500 for voltage levels of 0.8V (10V Offset) and 8V (10V Full).

Press [BUTTON]:



[Off]

[STOP] [TEST]

(Read Voltage from voltmeter. Example: 0.8V)

[0] [.] [8] [ENTER]

[STOP]



[Off]

[STOP] [TEST]

(Read Voltage from voltmeter. Example: 8.0V)

[8] [.] [0] [ENTER]

[STOP]

Display Reads:

Cal	LC	10V	Offset
0.8 V			

Step-01	D1	LO	0.0s
Disable	LC	6.000 mA	

Step-01	30.0s		
---------	-------	--	--

Step-01	30.0s		
---------	-------	--	--

Step-01	D1	LO	0.0s
Disable	LC	6.000 mA	

Cal	LC	10V	Full
8 V			

Step-01	D1	LO	0.0s
Disable	LC	6.000 mA	

Step-01	30.0s		
---------	-------	--	--

Step-01	30.0s		
---------	-------	--	--

Step-01	D1	LO	0.0s
Disable	LC	6.000 mA	

4.3.10 Leakage Current Power Meter Calibration

Connect the Fluke 5500 calibrator to the **L-IN** and **N-IN** LINE INPUT terminals on the 6000-04 scan unit. Program the Fluke 5500 for voltage levels of 20V (300V Offset) and 200V (300V Full).

4.3.10.1 LCV 300V Offset & Full:

Press [BUTTON]:



[Off]

[STOP] [TEST]

(Read Voltage from voltmeter. Example: 20.0V)

[2] [0] [.] [0] [ENTER]

[STOP]



[Off]

[STOP] [TEST]

(Read Voltage from voltmeter. Example: 200.0V)

[2] [0] [0] [.] [0] [ENTER]

[STOP]

Display Reads:

Cal	LCV	300V	Offset
20 V			

Step-01	D1	LO	0.0s
Disable	LC	6.000 mA	

Step-01	30.0s		
---------	-------	--	--

Step-01	30.0s		
---------	-------	--	--

Step-01	D1	LO	0.0s
Disable	LC	6.000 mA	

Cal	LCV	300V	Full
200 V			

Step-01	D1	LO	0.0s
Disable	LC	6.000 mA	

Step-01	30.0s		
---------	-------	--	--

Step-01	30.0s		
---------	-------	--	--

Step-01	D1	LO	0.0s
Disable	LC	6.000 mA	

Connect the Fluke 5500 calibrator to the **N-IN** and **N-OUT** terminals on the 6000-04 scan unit. Program the Fluke 5500 for current levels of 0.08A (1A Offset) and 0.8A (1A Full).

4.3.10.2 LCA 1A Offset & Full:

Press [BUTTON]:



[Off]

[STOP] [TEST]

(Read Current from current meter. Example:0.08 A)

[0] [.] [0] [8] [ENTER]

[STOP]



[Off]

[STOP] [TEST]

(Read Current from current meter. Example: 0.8 A)

[0] [.] [8] [ENTER]

[STOP]

Display Reads:

Cal	LCA	1A	Offset
0.08 A			

Step-01	D1	LO	0.0s
0.900 A	LC	6.000	mA

Step-01	30.0s
---------	-------

Step-01	30.0s
---------	-------

Step-01	D1	LO	0.0s
0.900 A	LC	6.000	mA

Cal	LCV	1A	Full
0.8 A			

Step-01	D1	LO	0.0s
0.900 A	LC	6.000	mA

Step-01	30.0s
---------	-------

Step-01	30.0s
---------	-------

Step-01	D1	LO	0.0s
0.900 A	LC	6.000	mA

4.3.10.3 LCA 10A Offset & Full:

Connect the Fluke 5500 calibrator to the **N-IN** and **N-OUT** terminals on the 6000-04 scan unit. Program the Fluke 5500 for current levels of 0.8A (10A Offset) and 8A (10A Full).

Press [BUTTON]:



[Off]

[STOP] [TEST]

(Read Current from current meter. Example:0.8 A)

[0] [.] [8] [ENTER]

[STOP]



[Off]

[STOP] [TEST]

(Read Current from current meter. Example: 8 A)

[8] [.] [0] [ENTER]

[STOP]

Display Reads:

Cal	LCA	10A	Offset	
0.8 A				

Step-01	D1	LO	0.0s	
10.00 A	LC	6.000 mA		

Step-01		30.0s		
---------	--	-------	--	--

Step-01		30.0s		
---------	--	-------	--	--

Step-01	D1	LO	0.0s	
10.00 A	LC	6.000 mA		

Cal	LCV	10A	Full	
8 A				

Step-01	D1	LO	0.0s	
10.00 A	LC	6.000 mA		

Step-01		30.0s		
---------	--	-------	--	--

Step-01		30.0s		
---------	--	-------	--	--

Step-01	D1	LO	0.0s	
10.00 A	LC	6.000 mA		

4.3.11 IR Resistor Calibration

Connect a 1G Ω load resistor between the HIGH (HV) and LOW (Drive-) terminals.

NOTE

Upon entering the calibrated value of the resistance standard, the G6200 unit may respond with a low limit failure. (FAIL LED lights, Display indicates "low limit failure"). This is normal. Proceed with remaining calibration steps.

IRR Range0 and Range1:

Press [BUTTON]:

Display Reads:



Cal IRR Range 0
1.00 G Ω

[Off]

Step-01	0.0s
0.250kV IR	1.0 M Ω

[STOP] [TEST]

Step-01	30.0s
---------	-------

(Enter calibrated value of resistance standard. Example: 1000.01Mhms)

[1] [0] [0] [0] [.] [0] [0] [ENTER]

Step-01	30.0s
---------	-------

[STOP]

Step-01	0.0s
0.250kV IR	1.0 M Ω

(Change Load Resistor to 100M Ω)



Cal IRR Range 1
100.0 M Ω

[Off]

Step-01	0.0s
0.500kV IR	1.0 M Ω

[STOP] [TEST]

Step-01	30.0s
---------	-------

(Enter calibrated value of resistance standard. Example: 100.01Mohms)

[1] [0] [0] [.] [0] [0] [ENTER]

Step-01	30.0s
---------	-------

[STOP]

Step-01	0.0s
0.500kV IR	1.0 M Ω

IRR Range2 and Range3:

Change the load resistor to 10MΩ

Press [BUTTON]:



[Off]

[STOP] [TEST]

(Enter calibrated value of resistance standard. Example: 10.01Mhms)

[1] [0] [.] [0] [1] [ENTER]

[STOP]

(Using the same 10MΩ load resistor)



[Off]

[STOP] [TEST]

(Enter calibrated value of resistance standard. Example: 10.01Mhms)

[1] [0] [.] [0] [1] [ENTER]

[STOP]

Display Reads:

Cal IRR	Range 2
10.0 M Ω	

Step-01	0.0s
0.500kV IR	1.0 M Ω

Step-01	30.0s
---------	-------

Step-01	30.0s
---------	-------

Step-01	0.0s
0.500kV IR	1.0 M Ω

Cal IRR	Range 3
10.0 M Ω	

Step-01	0.0s
1.000kV IR	1.0 M Ω

Step-01	30.0s
---------	-------

Step-01	30.0s
---------	-------

Step-01	0.0s
1.000kV IR	1.0 M Ω

4.3.12 Finalize Calibration

Press [BUTTON]:

[ENTER] [7] [9] [3] [1]

[Off]

[PROG] (to exit Calibration)

Display Reads:

Calibrate is Test Press OFF key.

Calibrate is ON Press OFF key.

Step-01	0.0s
1.000kV WAC	3.0mA

Press the lock switch labeled Cal-Enable (to the **OUT** position) and cover with a calibration label.

NOTE

Pressing the [↑] key at any time during calibration permits the operator to scroll through the calibration steps.
The [OFF] key enters the operator into that particular calibration step.
The [STOP] key accepts the calibration value.

4.4 Error Messages

Possible error messages for the Guardian 6000 Series instrument family are divided into two categories. There is a set of error messages that apply to the normal operation of the instrument and a second set of error messages that apply to the operation of the instrument with a GPIB (IEEE-488) Interface installed. Refer to Table 4-3.

Table 4-3: Error Messages

Operation	Error Number	Message Description
Normal	100	HARDWARE FAILURE Consult QuadTech for SERVICE
	101	
	102	
	Discharging	
GPIB	Error 0	Save OK!
	Error 1	The command is INVALID!
	Error 2	The parameter is INVALID!
	Error 3	TEST can NOT be initiated!
	Error 4	Scan Box is NOT CONNECTED!
	Error 5	Can NOT set Channel # to ZERO!
	Error 6	Set Channel HIGH OR LOW, NOT BOTH!
	Error 7	No DATA to RECALL! (No Data stored in recall location)
	Error 8	No MEMORY for STORAGE! (Invalid memory location)